

SNOWSOUND



CB SOFA



ACOUSTIC SOFA

This innovative sound-absorbing sofa designed by Claudio Bellini stands out for its generous form and cylindrical sections, granting immersive comfort and relaxation. Drawing on Caimi's consolidated experience in the sector, CB Sofa has been designed for the purposes of superior acoustic comfort, and functions as a haven of peace and privacy. Its structure integrates high-quality sound-absorbing materials covered in Snowsound Fiber acoustic fabric that minimise reverberation and ambient noise. The refined ergonomics of the high backrest offers ate an oasis of quiet in lively environments





PRODUCT SPECS: CB SOFA

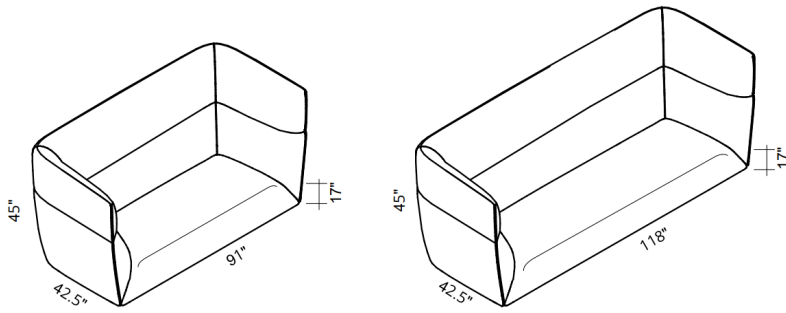

FABRIC FINISH: FIBER 8 BOUCLÈ

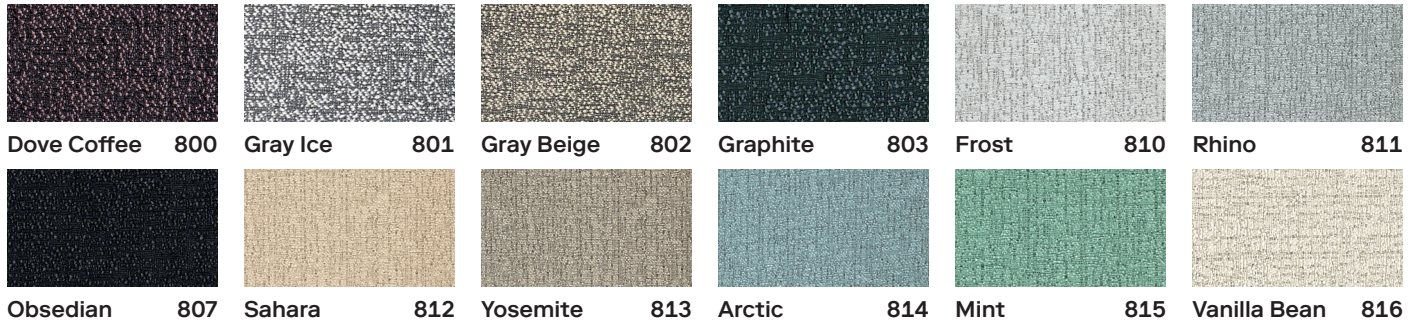

PHYSICAL PROPERTIES

Content 100% Inherently Fire Resistant, Acoustic Sound Absorbing Polyester Fibers with Patented Snowsound Technology

ACOUSTIC PERFORMANCE & NOISE REDUCTION RATING

Absorption Coefficient & NRC Please refer to the online Technical Sheets for acoustical testing details

PERFORMANCE

Flame Resistance	Passes NFPA 701 // NFPA 260 // CAL. TB 117 // UL 723 Class A // ASTM E 84 Class A
Environment	100% Recyclable and GREENGUARD GOLD Certified LEED v4 Credits and Certification, Declare Label, LBC Red List Free
Abrasion Resistance	25,000 rubs /cycles (tested according to Martindale Method)
Colorfastness to Light	Grade 6/7 – “Excellent” (Passes AATCC 16 / ISO 105-B02:2014)
Colorfastness to Crocking	Wet & Dry – Grade 5 (Passes AATCC 8 / ISO 105-X12: 2016)
Propensity to Surface Fuzzing & Pilling	Grade 5 – “no change” (Passes ISO 12945-2:2002)



FABRIC FINISH: FIBER 14 BIOSPHERE

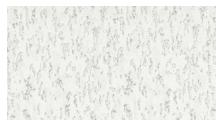

Stone

1401

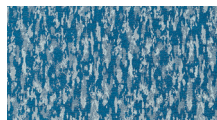

Clouds

1402

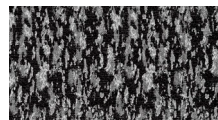

Volcano

1404



Tundra

1405



Forest

1406

PHYSICAL PROPERTIES

Content 100% Inherently Fire Resistant, Acoustic Sound Absorbing Polyester Fibers with Patented Snowsound Technology

ACOUSTIC PERFORMANCE & NOISE REDUCTION RATING

Absorption Coefficient & NRC Please refer to the online Technical Sheets for acoustical testing details

PERFORMANCE

Flame Resistance Passes NFPA 701 // NFPA 260 // CAL. TB 117 // UL 723 Class A // ASTM E 84 Class A

Environment 100% Recyclable and GREENGUARD GOLD Certified
LEED v4 Credits and Certification, Declare Label, LBC Red List Free

Abrasion Resistance 25,000 rubs /cycles (tested according to Martindale Method)

Colorfastness to Light Grade 6/7 – “Excellent” (Passes AATCC 16 / ISO 105-B02:2014)

Colorfastness to Crocking Wet & Dry – Grade 5 (Passes AATCC 8 / ISO 105-X12: 2016)

Propensity to Surface Fuzzing & Pilling Grade 5 – “no change” (Passes ISO 12945-2:2002)



SNOWSOUND

SNOWSOUND USA HQ
Snowsound USA
10018 Santa Fe Springs Road
Santa Fe Springs, CA 90670
Tel. 562.903.9550
info@snowsoundusa.com
www.snowsoundusa.com



Declare.

Scan for more products



Hear the difference



LOS ANGELES SHOWROOM
Pacific Design Center
Green Building, Suite G-152
8687 Melrose Ave
West Hollywood, CA 90069

CHICAGO SHOWROOM
222 Merchandise Mart Plaza
Floor 11, Suite 1197
Chicago, IL 60654 USA

NEW YORK SHOWROOM
New York Design Center (NYDC)
200 Lexington Ave
Floor 11, Suite 1106
New York, NY 10016 USA

©2024 Snowsound USA. All rights reserved.
Follow us: @snowsoundusa

