

CUBBY



CUBBY



CUBBY is a comfortable phone booth composed of panels featuring sound-absorbing polyester foam covered in an external sound-absorbing polyester fabric, which is easy to clean. It also includes an independent load-bearing angled shelf made of powder-coated steel. The soft side-panels can move freely if bumped.

Specs	Polyester internal padding with Snowsound technology, polyester covering in Trevira CS® fabric
	Single material and 100% recyclable
	Eco friendly – Greenguard Gold
	Durable, tackable double-sided surface
	Class A fire and smoke safety (UL 723/ASTM E84)
	CAL 133, 117 pass
	Sleek profile at only 1.4” thick
Designer	Snowsound Lab

CUBBY COMPLETE KIT

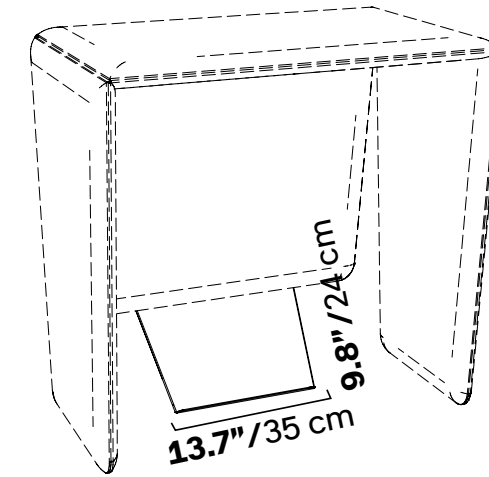
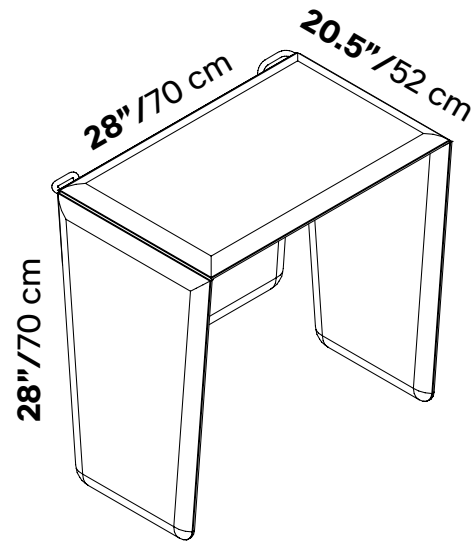

	Color	Part No
	Silver	40020098
	Gray	
	Red	40020097
	Gray	7CK700-300**
	Ice	
	Azure	7CK700-305**
	Gray	7CK700-308**
	Blue	
	Gray	7CK700-309**
	Green	
	Patina	7CK700-312**
	Carbon	7CK700-311**
	Gray	

Optional angled shelf

Part No	40021090
QTY	01 Pair
Finish	Chrome

** Extended lead time
 Extended lead time colors require: up to 10-12 weeks

Quick Ship items only show item number without additional notation
 For larger swatches & full color options, please refer to pages 32-34 and pages 300-303.