

<p>4002xxxx</p>  <p>x1</p>	<b>x1</b>					
<p>4002xxxx</p>  <p>x1</p>		<b>x1</b>				
<p>4002504X</p>  <p>x1</p>			<b>x1</b>		<b>x1</b>	
<p>4002504X</p>  <p>x1</p>				<b>x1</b>		<b>x1</b>
<p>40025027</p>  <p>32.2 in.</p> <p>x2</p> <p>f x16 h x8</p>		<b>x1</b>	<b>x1</b>		<b>x1</b>	
<p>40025028</p>  <p>47.9 in.</p> <p>x2</p> <p>f x16 h x8</p>	<b>x1</b>			<b>x1</b>		<b>x1</b>
<p>40025152</p>  <p>24 in.</p> <p>x2</p> <p>g x4</p>	<b>x1</b>	<b>x1</b>				
<p>40025026</p>  <p>32.2 in.</p> <p>x2</p> <p>g x4</p>			<b>x1</b>	<b>x1</b>	<b>x1</b>	<b>x1</b>
<p>40025025</p>  <p>i x1 n x2 m x2</p>					<b>x1</b>	<b>x1</b>
<p>40024006</p>  <p>p x1 q x1 r x1 t x1</p>	<b>x4</b>	<b>x4</b>	<b>x4</b>	<b>x4</b>		

**Upsize Ceiling**

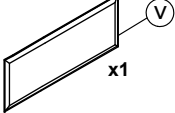

**Upsize Wall**

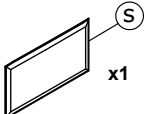
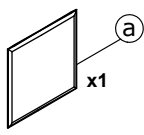
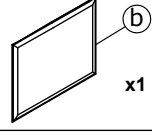
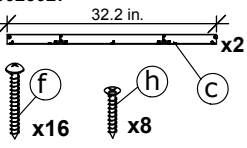
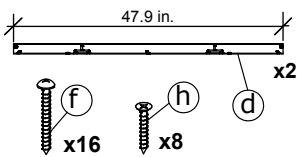
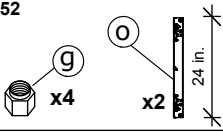
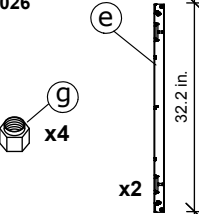
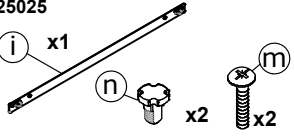
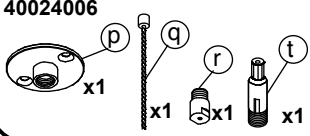
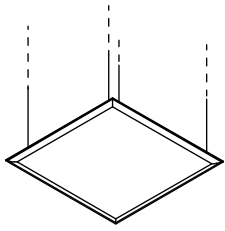
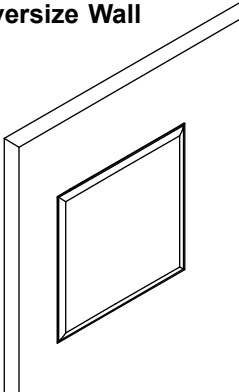

**1a**

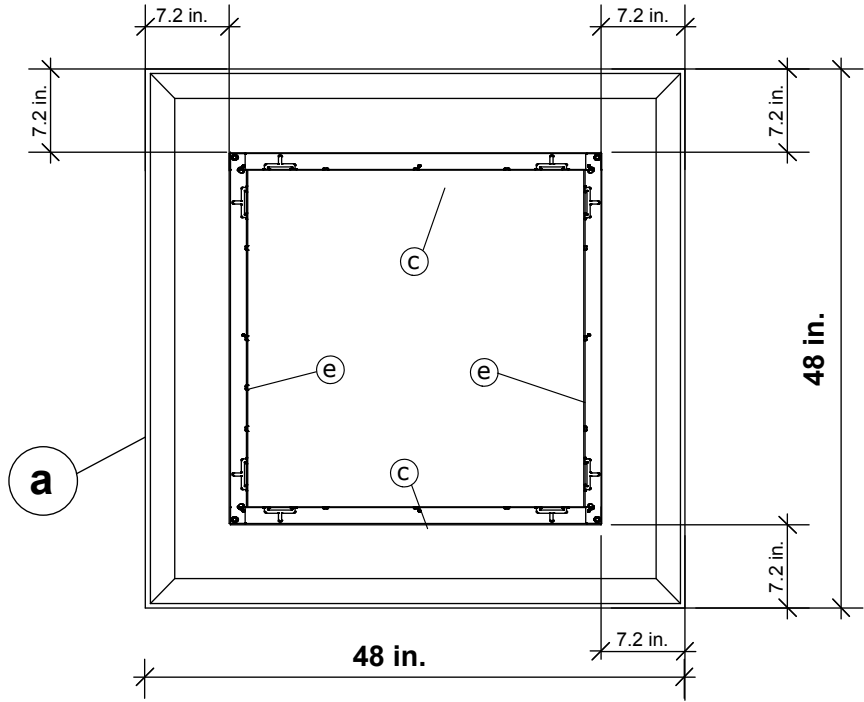

**Upsize Ceiling**

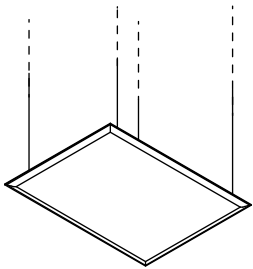

**Upsize Wall**

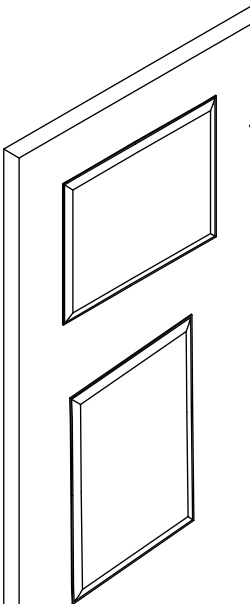

**1b**

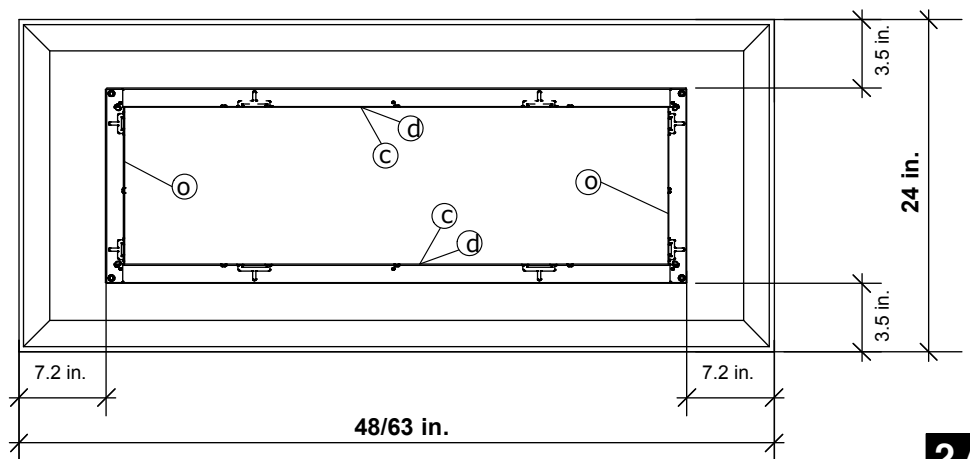
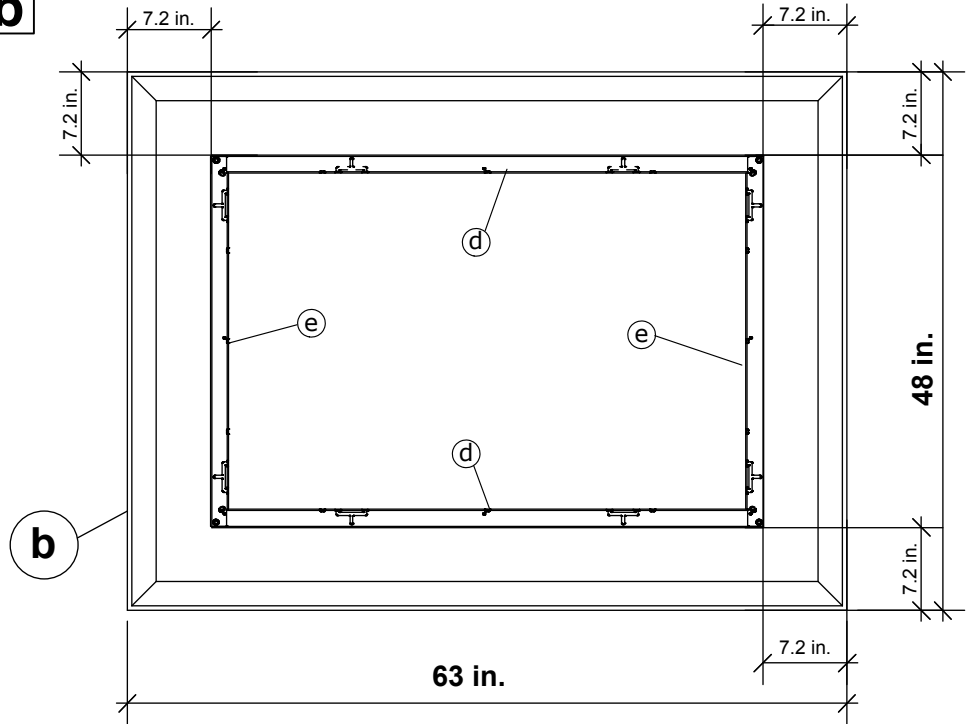

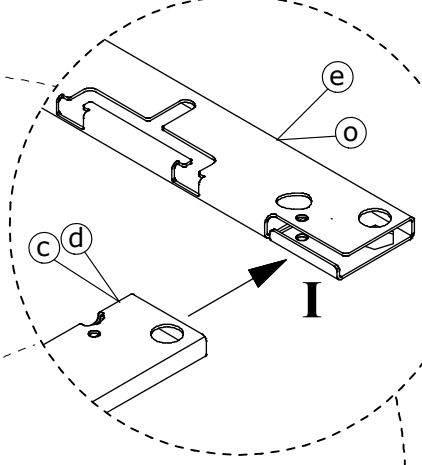
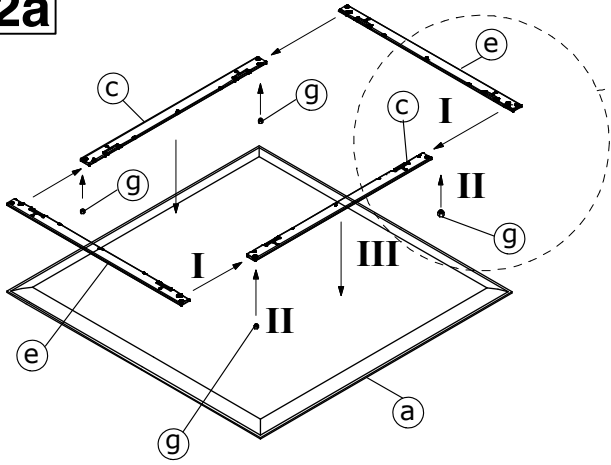
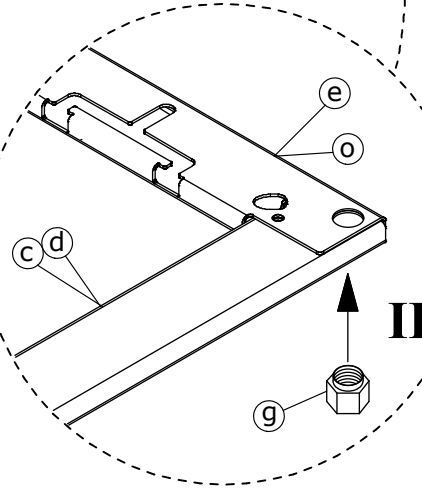
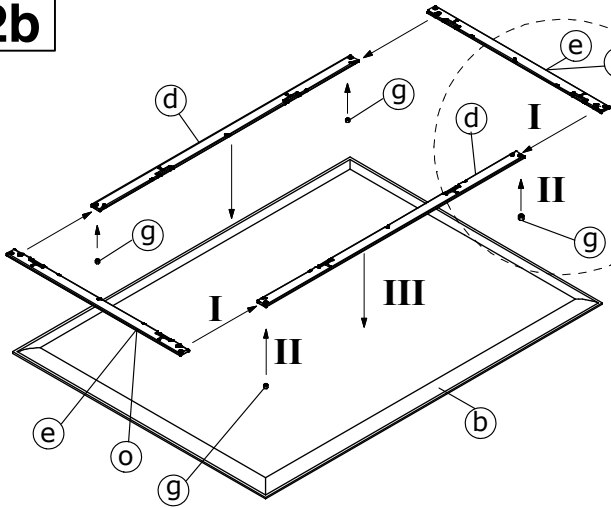
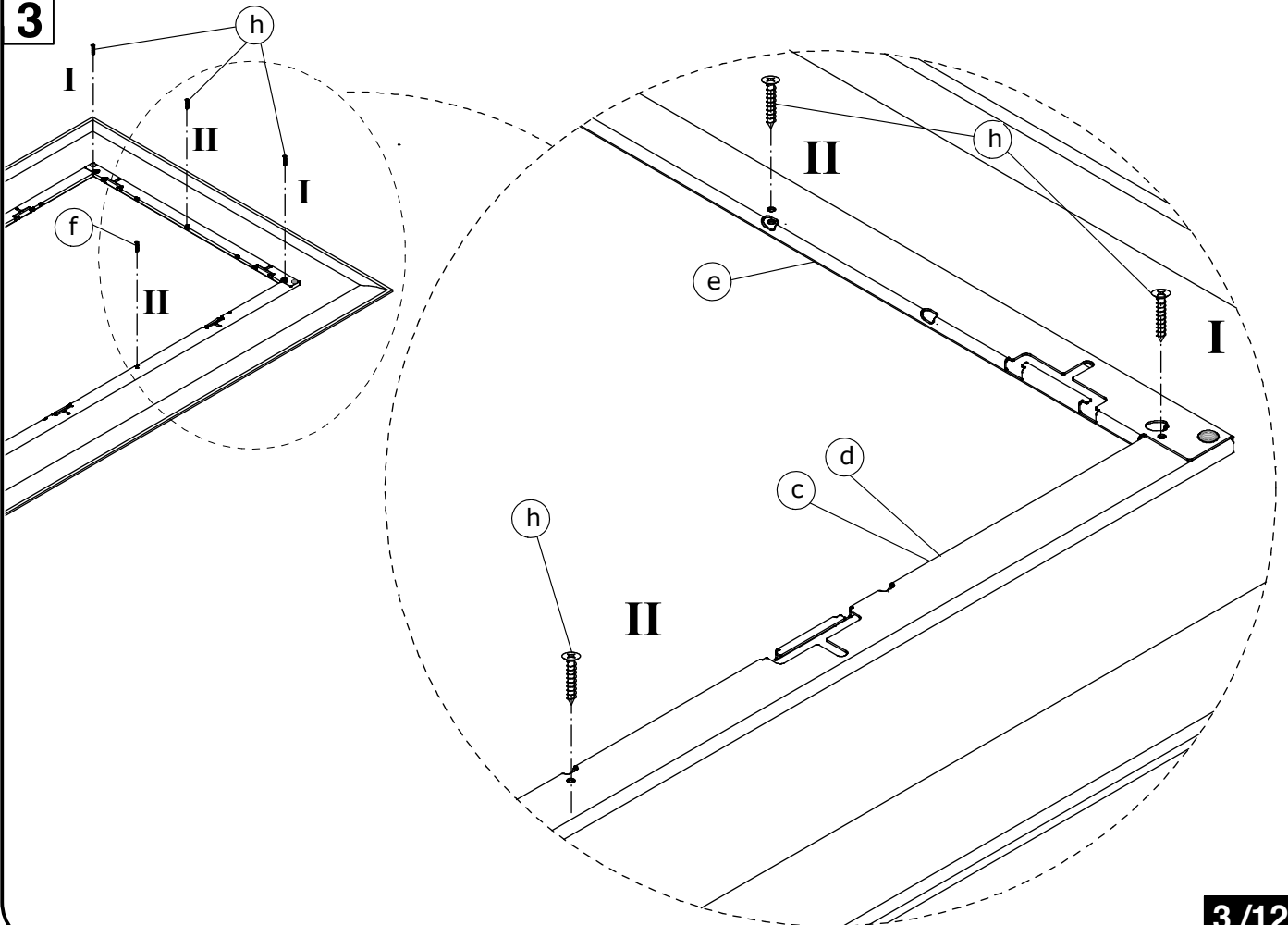
**2a****2b****3**

4

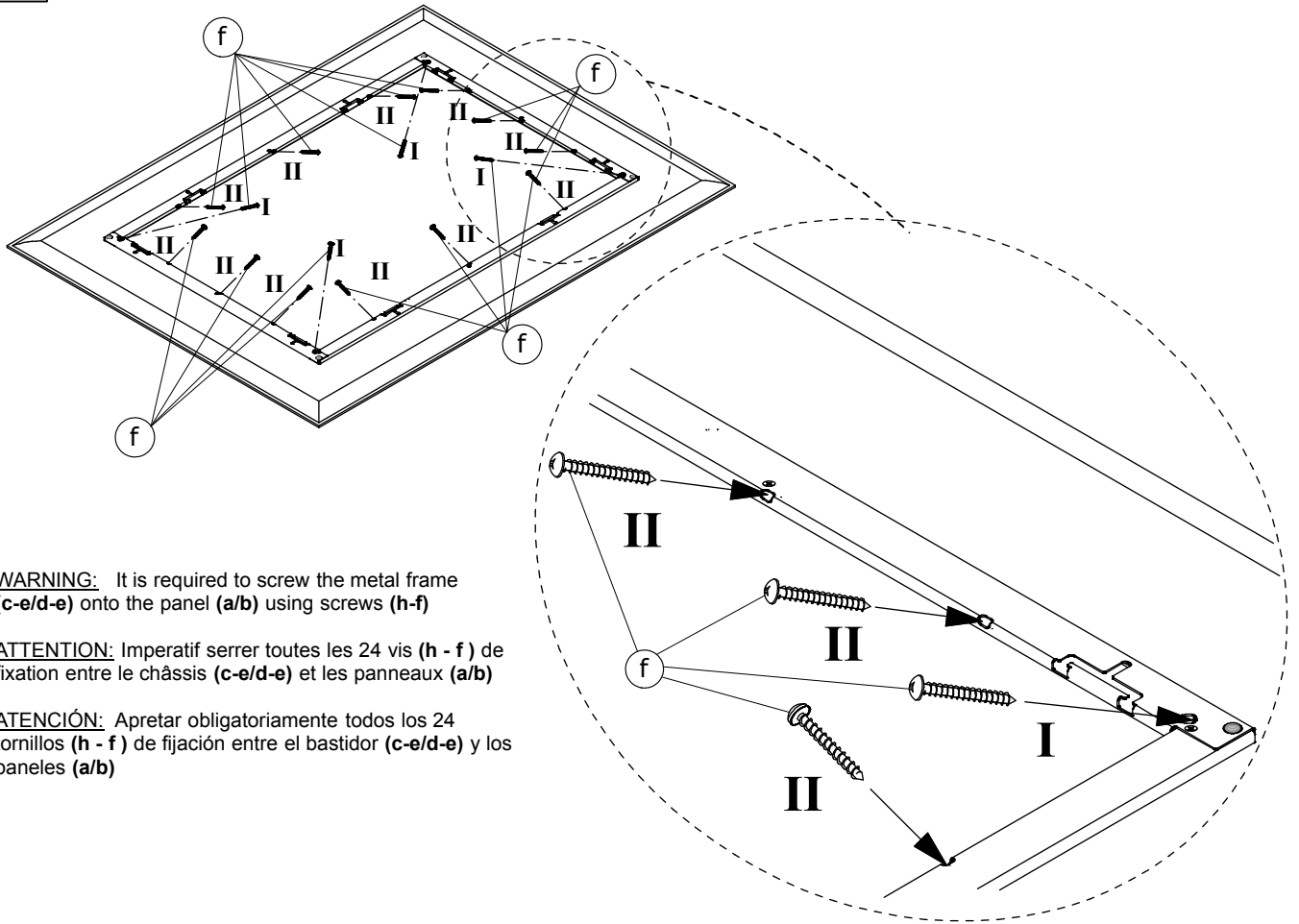

**WARNING:** It is required to screw the metal frame (c-e/d-e) onto the panel (a/b) using screws (h-f)

**ATTENTION:** Imperatif serrer toutes les 24 vis (h - f) de fixation entre le châssis (c-e/d-e) et les panneaux (a/b)

**ATENCIÓN:** Apretar obligatoriamente todos los 24 tornillos (h - f) de fijación entre el bastidor (c-e/d-e) y los paneles (a/b)

5

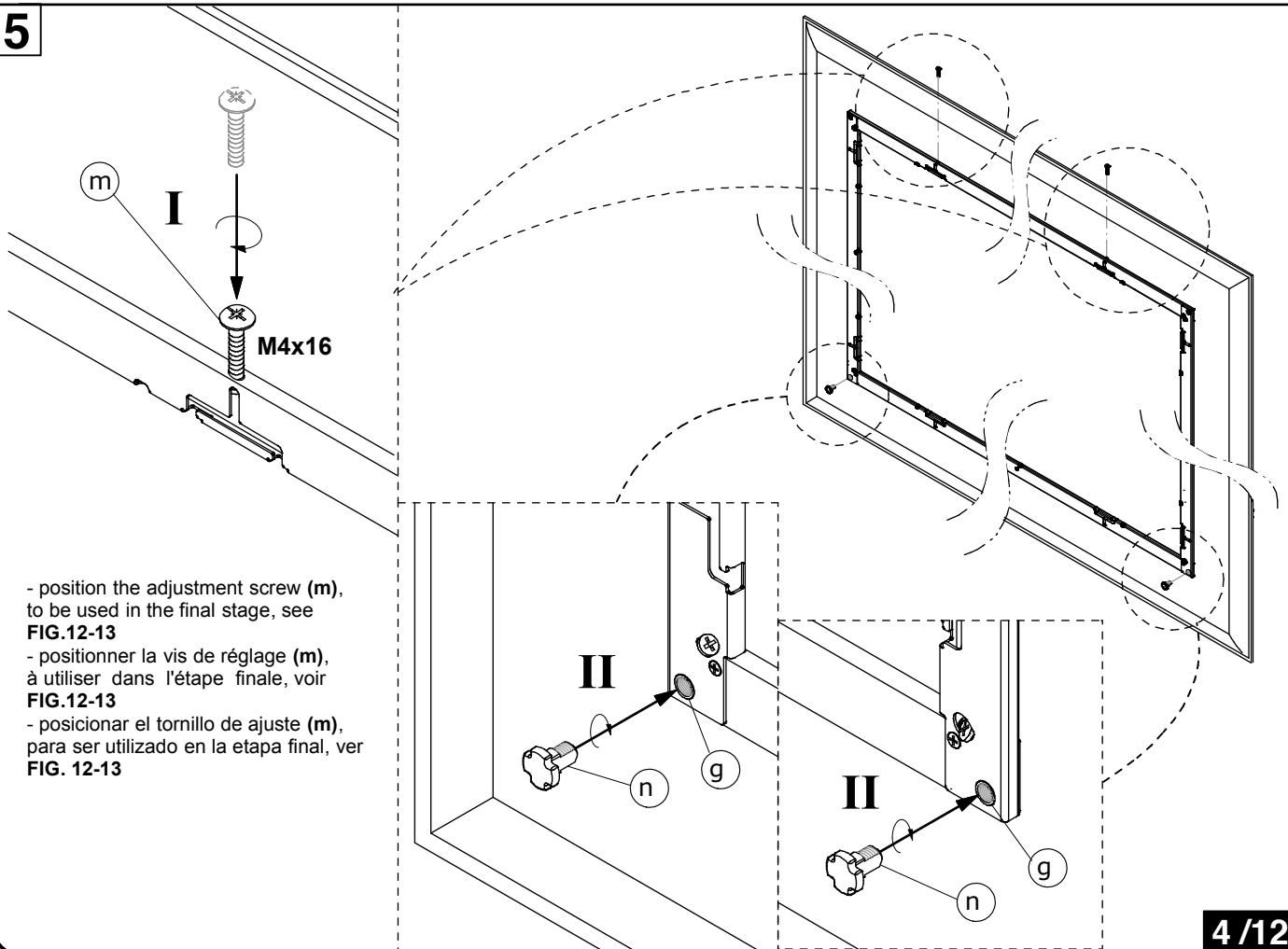

- position the adjustment screw (m), to be used in the final stage, see FIG.12-13
- positionner la vis de réglage (m), à utiliser dans l'étape finale, voir FIG.12-13
- posicionar el tornillo de ajuste (m), para ser utilizado en la etapa final, ver FIG. 12-13

6

Oversize Wall

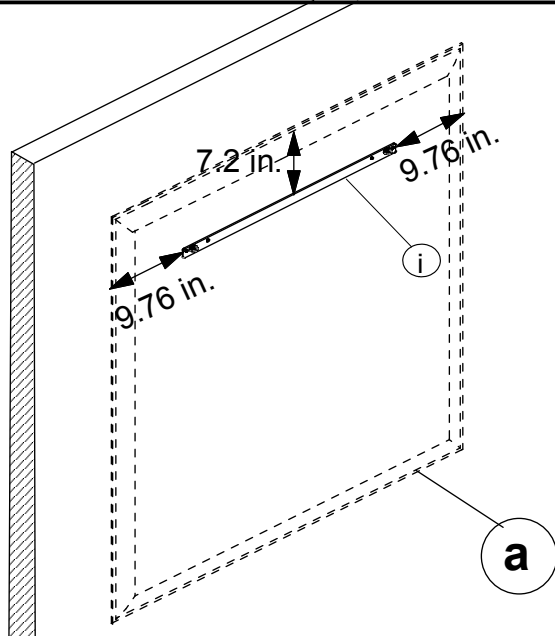
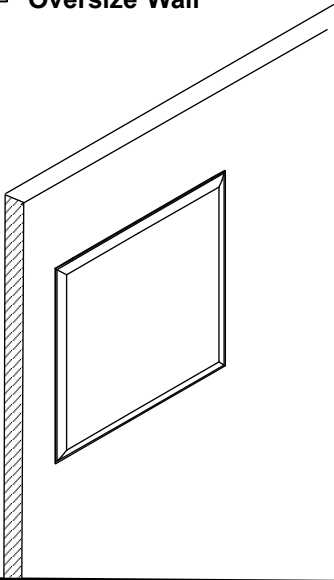

6

Oversize Wall

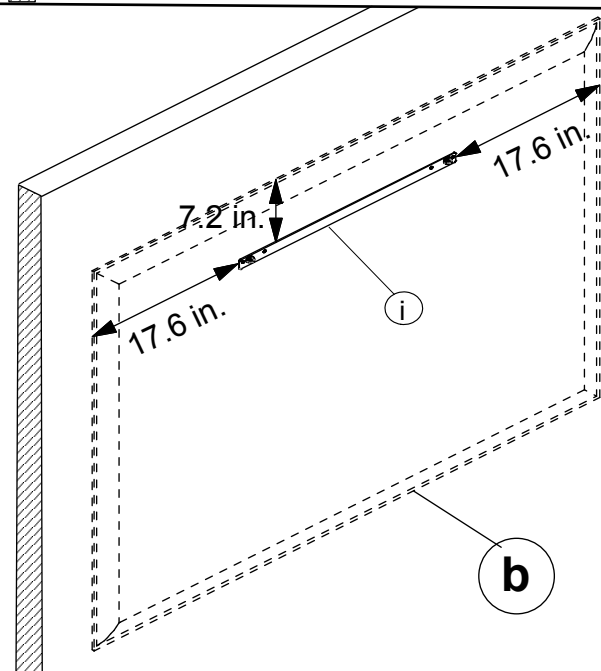
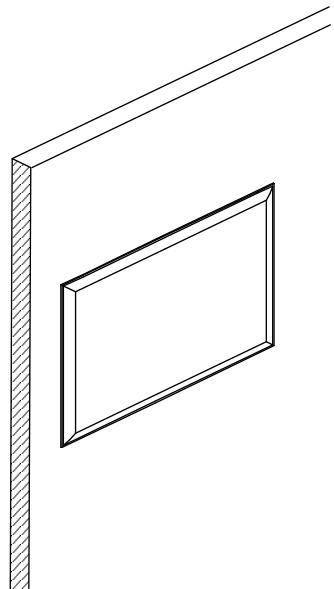

6

Oversize Wall

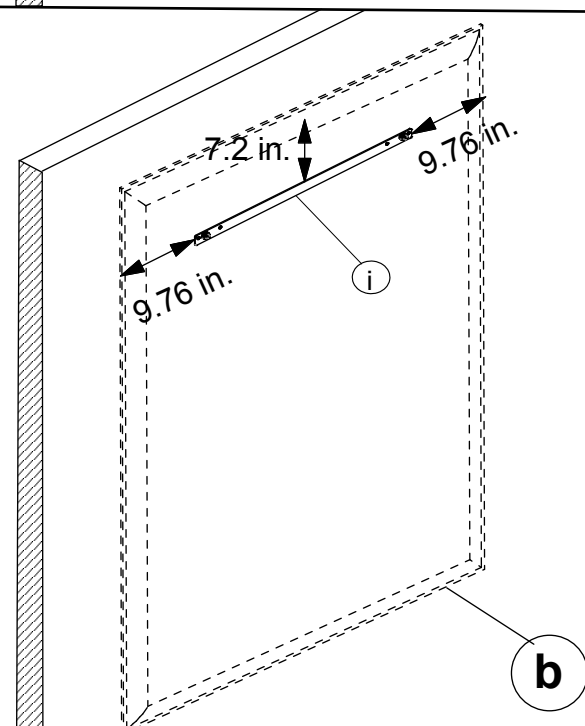
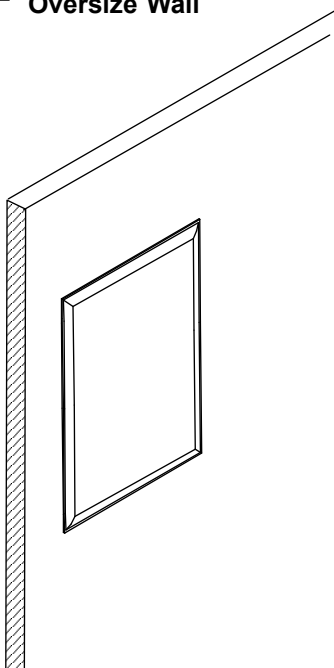

7

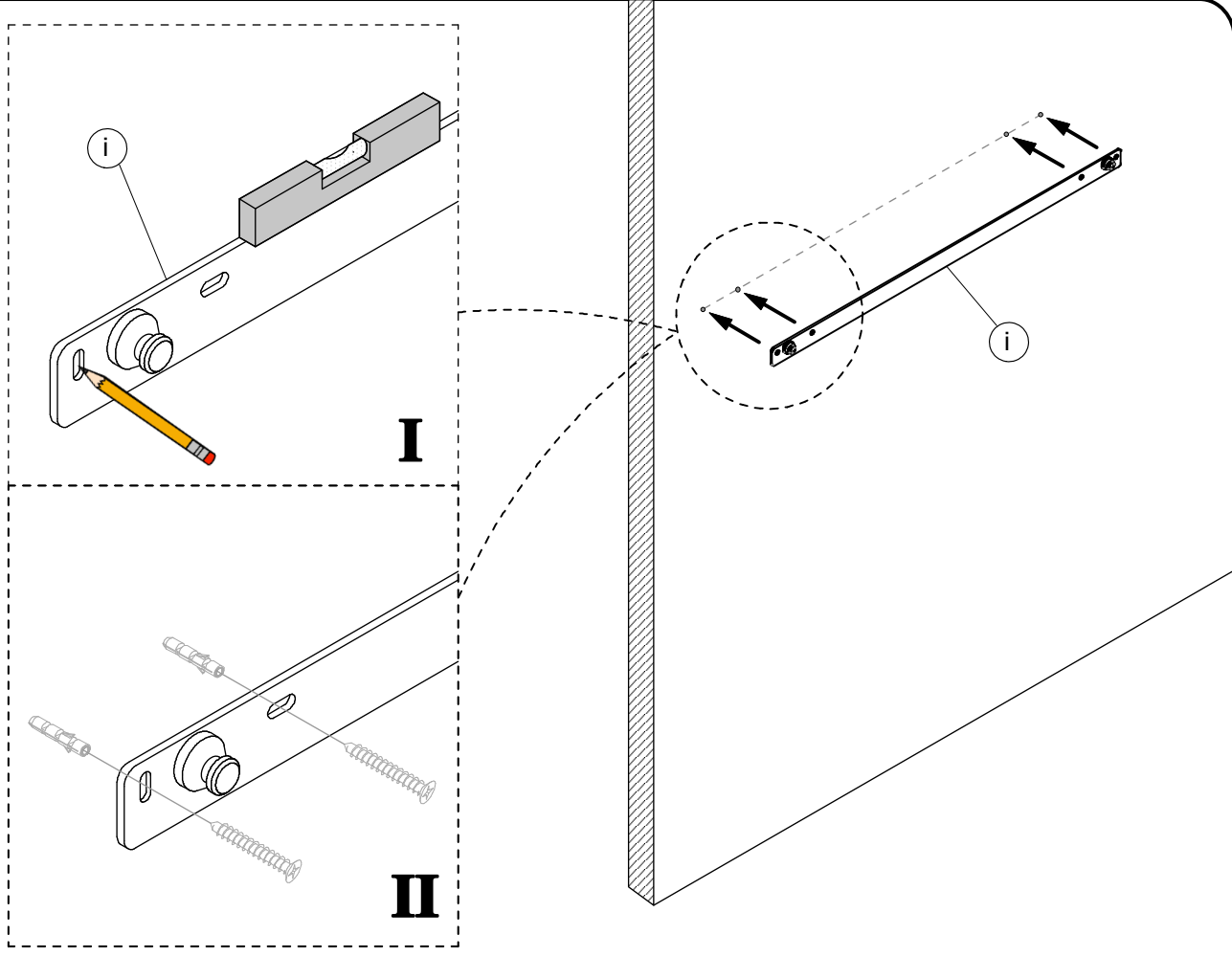

8

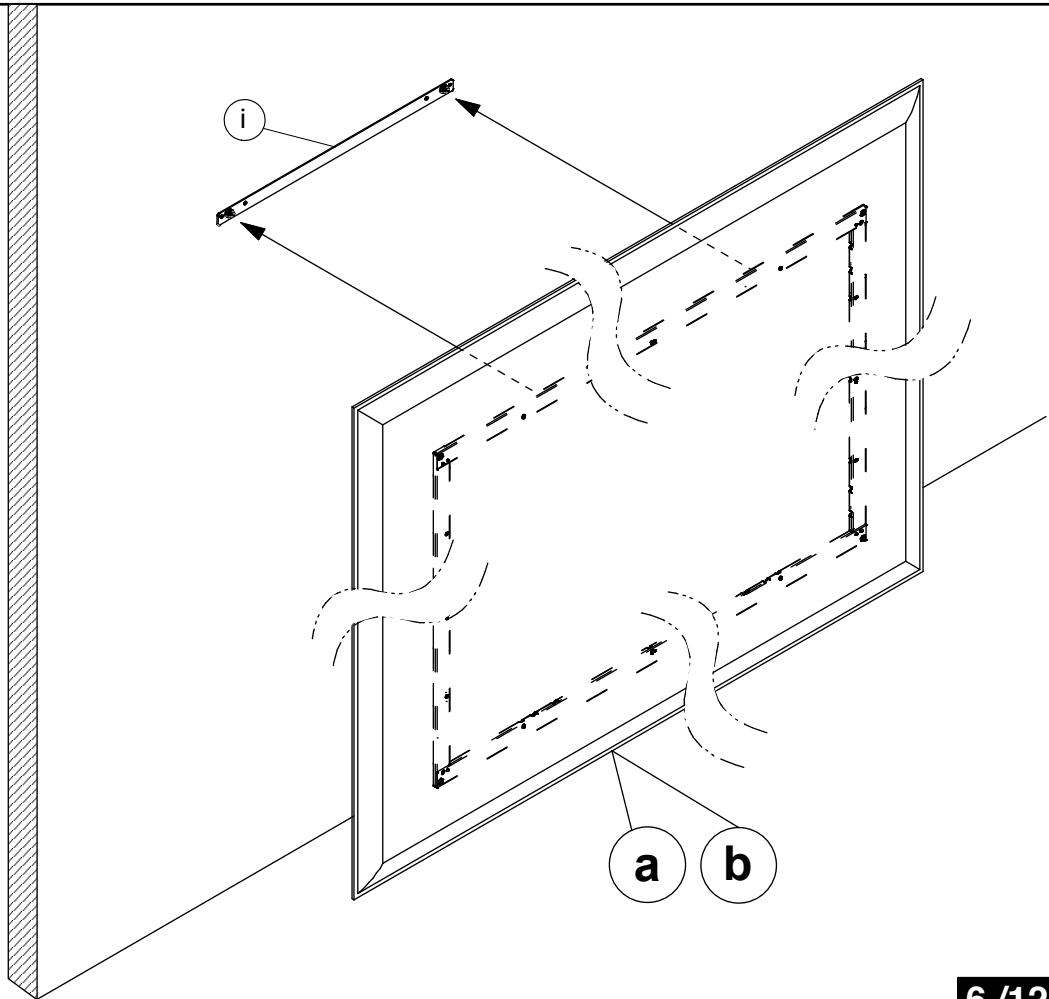

9

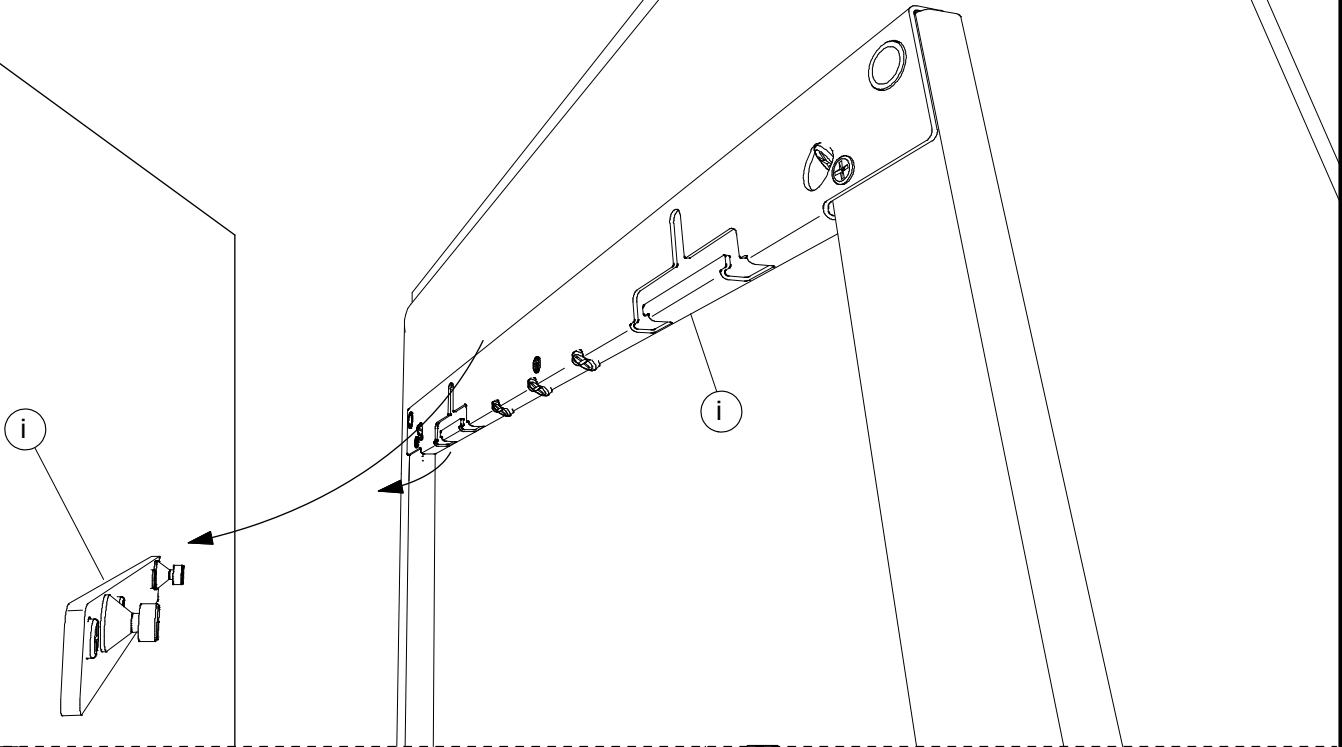

10

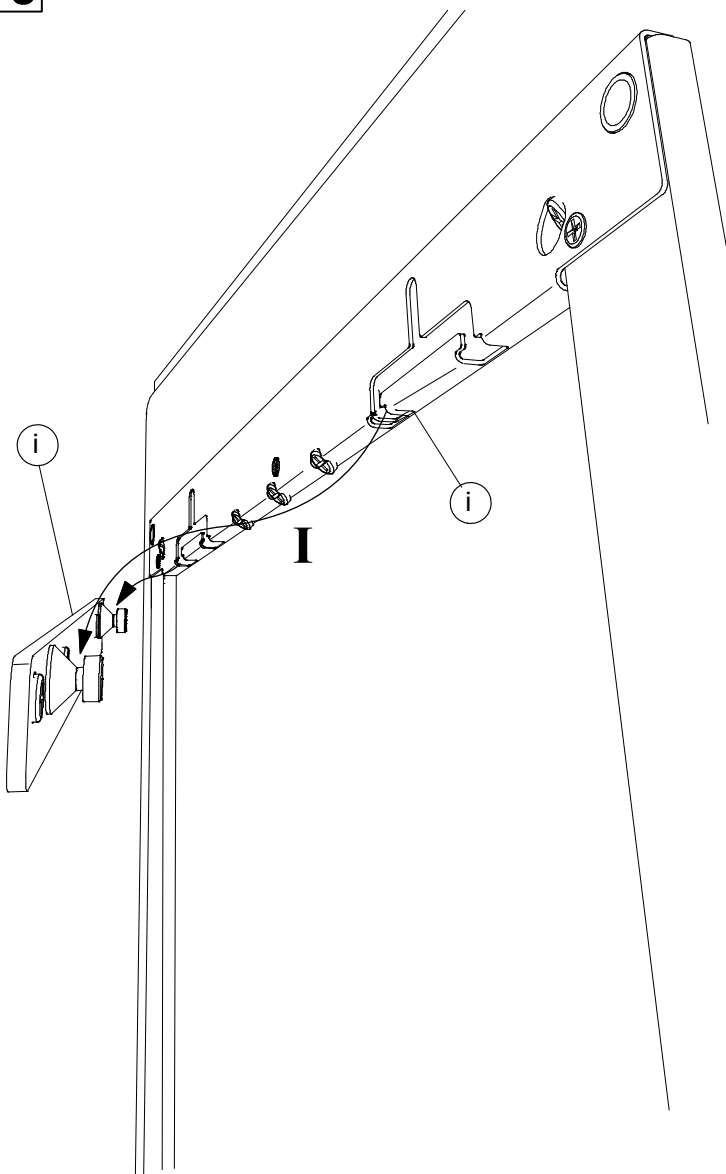

11

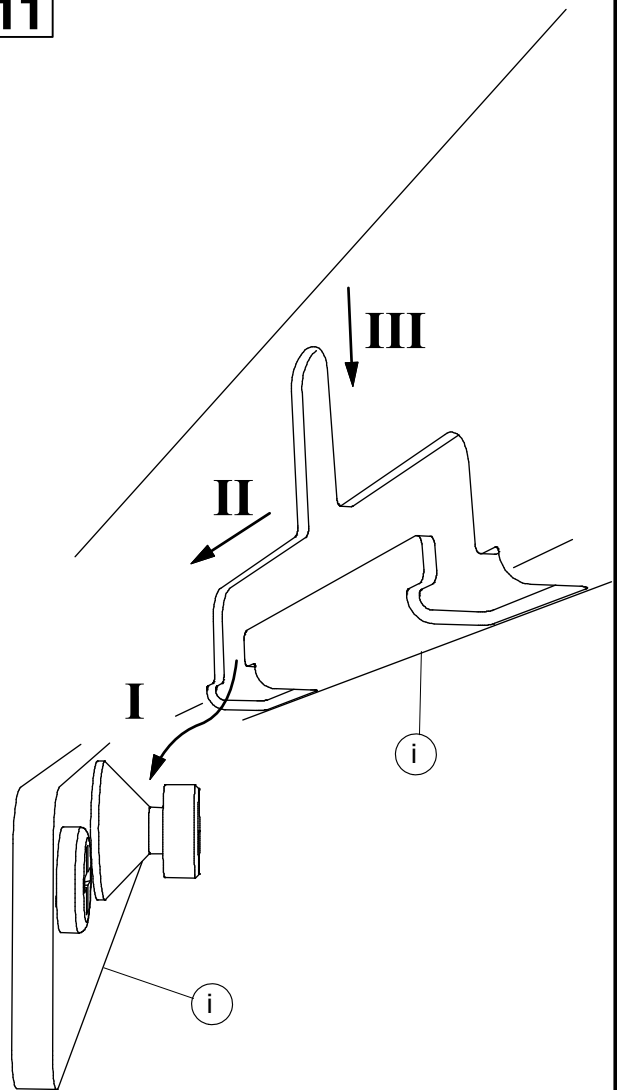

12

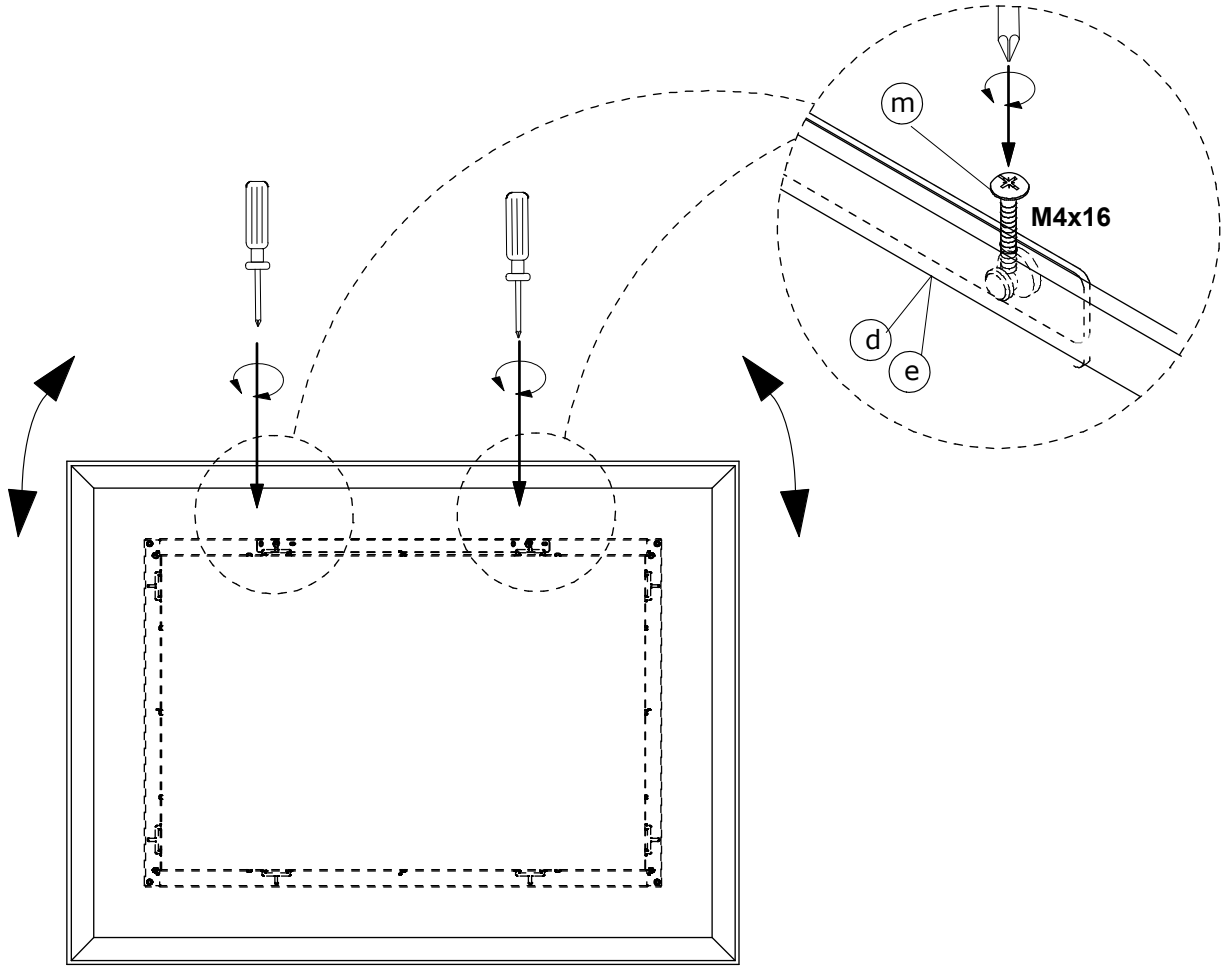

13

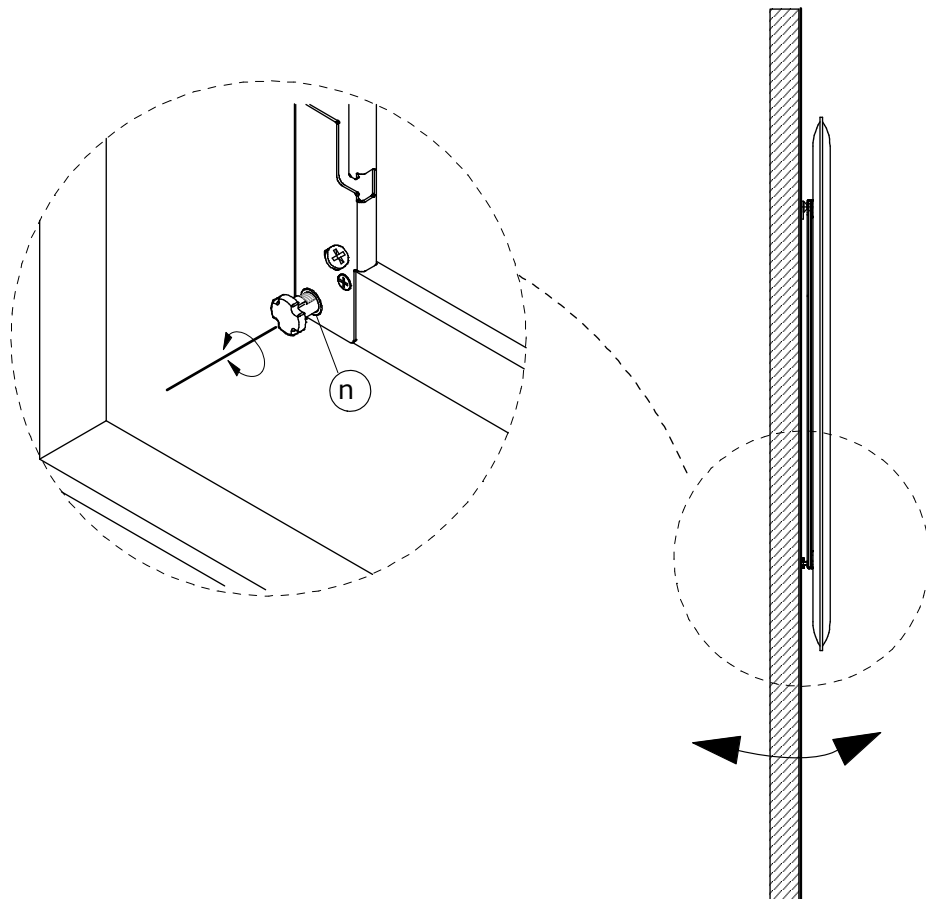



14

Oversize Ceiling

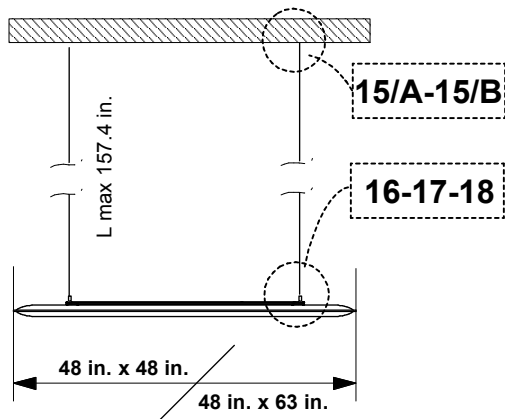
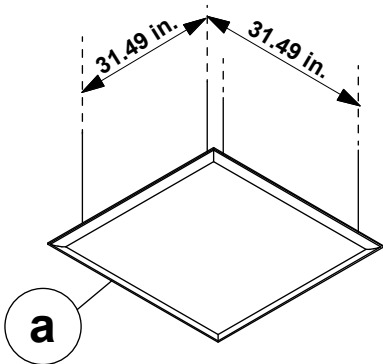

40024006

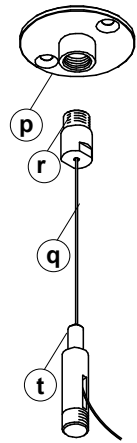

Oversize Ceiling

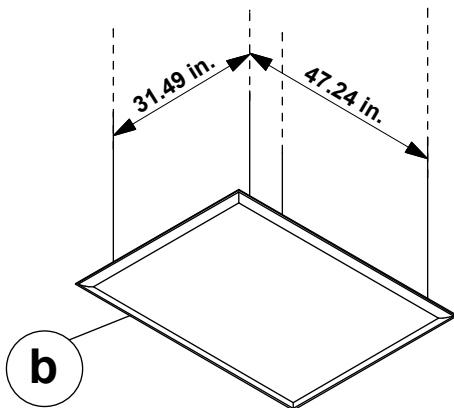

Oversize Ceiling

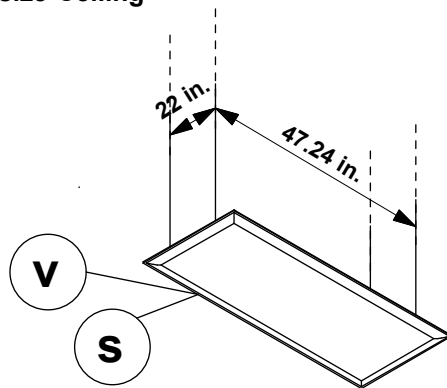

15/A

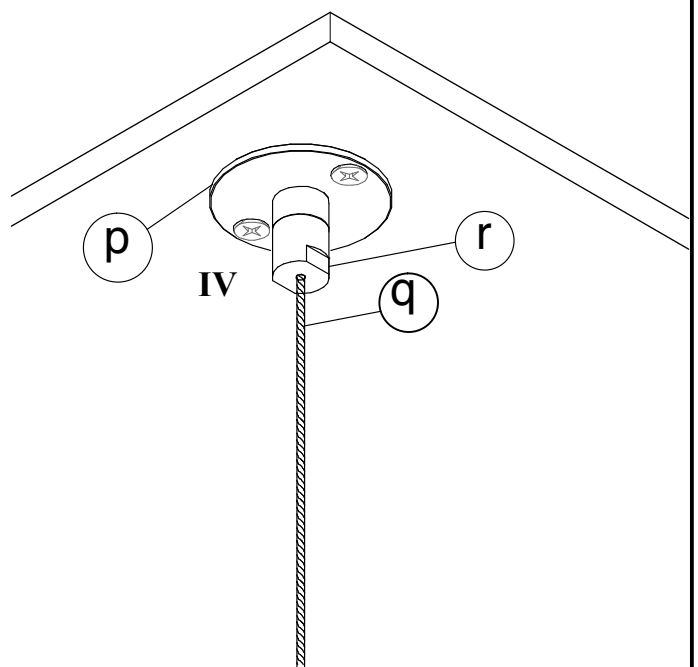
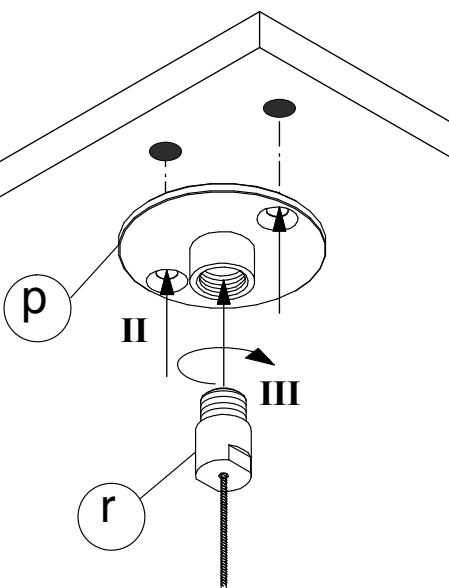
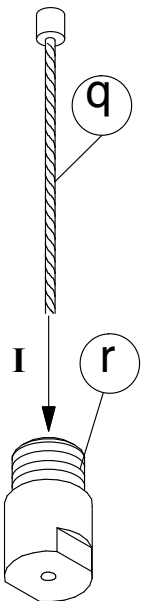

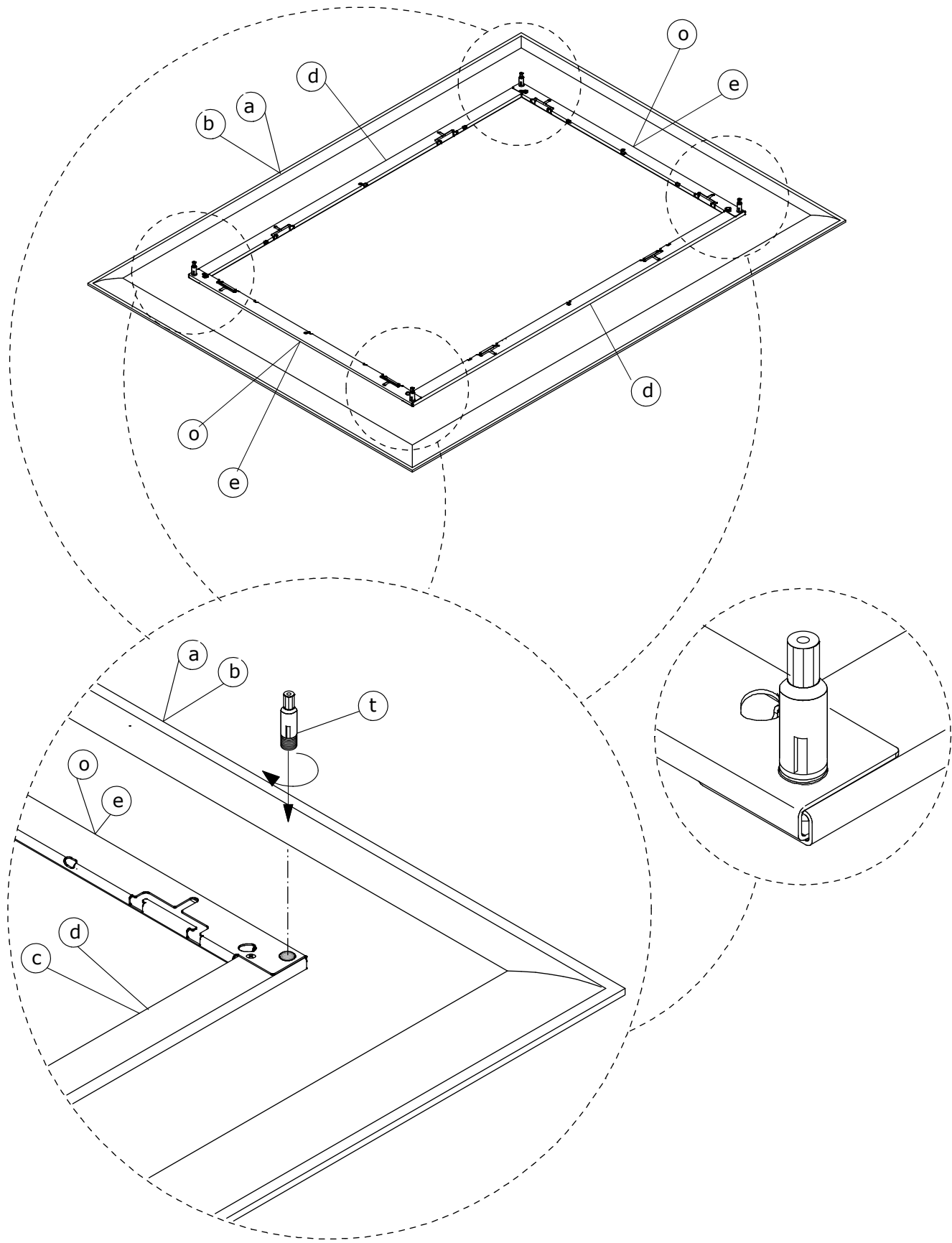

17

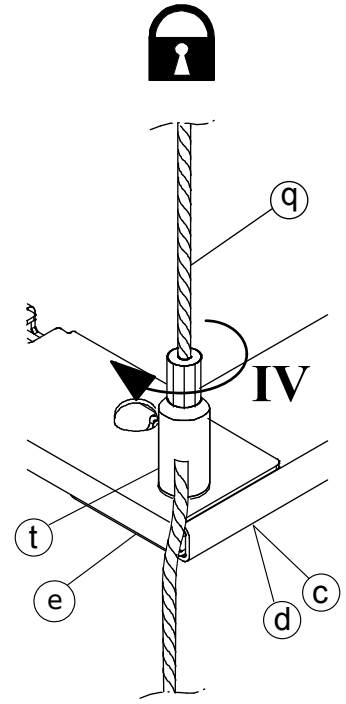
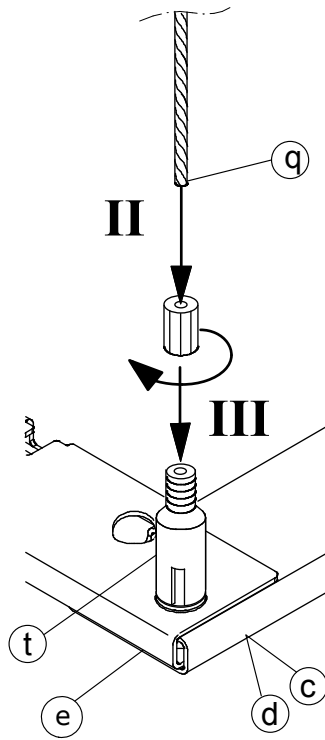
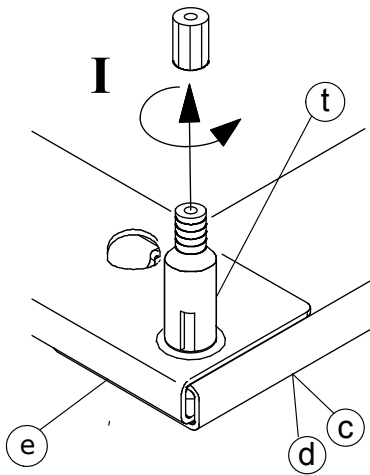

18

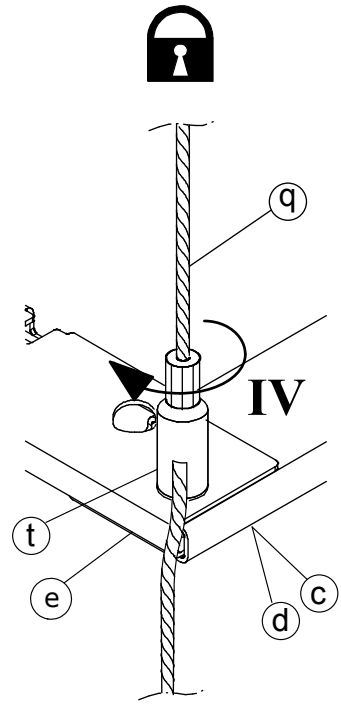
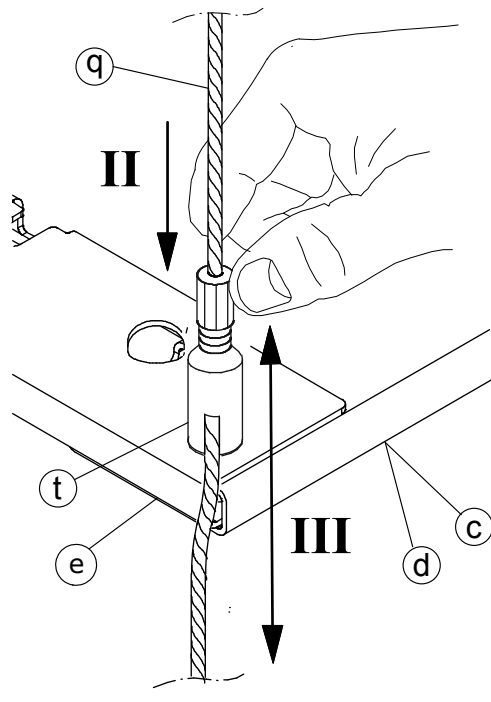
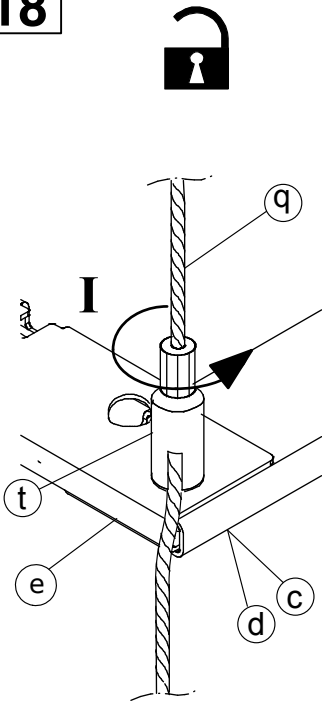

19

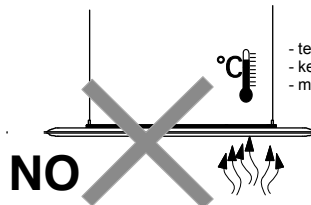
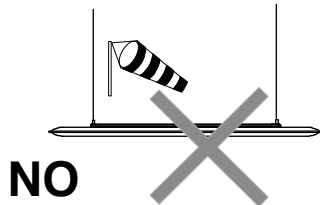
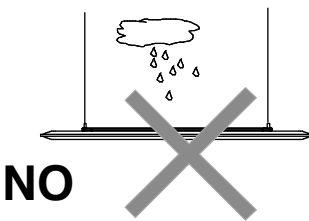
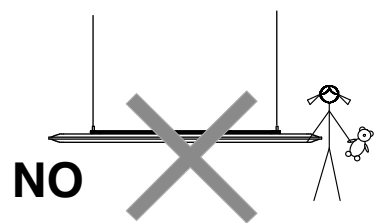
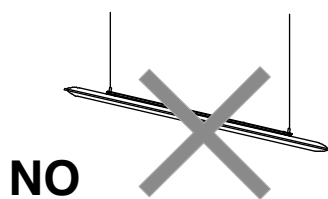
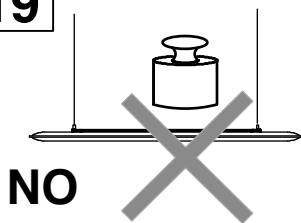

- tenere lontano da fonti di calore  
 - keep away from heat sources  
 - mantener alejado de fuentes de calor

Congratulations on your latest SNOWSOUND purchase. Follow these instructions and you'll have this new product mounted in no time. If you need any help, or to order replacement/missing parts, please call **1-800-747-2660** or email "[info@snowsoundusa.com](mailto:info@snowsoundusa.com)"

#### **NOTE!**

**Prior to assembling and installing the unit please read the following notes carefully. Pay particular attention to the drawings in the assembly instructions. Please consult these notes every time the product is assembled and/or installed.**

1. The product must only be assembled and installed by qualified contractors. Warning: once the product has been assembled always check that the structure is suitable for the type of application and/or use to which it will be put. These products are not suitable for use by children.
2. Prior to installation check the load bearing capacity of the surface on which the product is to be fitted :use suitable fixtures according to the type of surface which must be able to withstand the forces generated.
3. Warning: if you have any doubts concerning how to install the product and/or the load bearing capacity of the surface on which it will fitted, do not fit it. 4. **Do not use detergents to clean the parts that are not in textile fabric.** Use only a cloth damp with water.
5. **To clean the panel** use only a dry stain removal, carefully following the instructions on the product used.
6. For further information on how to install the product, please contact your dealer. For any use different from the ones here shown please contact the dealer.
7. To complete the assembling of the products please follow the instructions related to the chosen support

#### **MISES EN GARDE!**

**Avant de procéder au montage et à l'installation du produit, lire attentivement les mises en garde ci-dessous présentées, en faisant particulièrement attention aux dessins explicatifs rapportés dans les instructions de montage. Consulter ces mises en garde lors de chaque montage successif et/ou installation du produit.**

1. Le montage et l'installation du produit doivent exclusivement être effectués par un personnel technique compétent. Attention: au terme du montage, toujours vérifier si la structure réalisée est appropriée au type d'usagers et/ou d'utilisation auxquels elle est destinée. Les produits ne sont pas destinés aux enfants.
2. Avant de procéder à l'installation, il est nécessaire de vérifier la capacité de charge de la surface sur laquelle le produit sera installé :en conséquence, utiliser les dispositifs de fixation adaptés au type de surface et qui peuvent résister aux forces produites.
3. Attention: en cas de doute sur les modalités d'installation et/ou sur la capacité de charge de la surface sur laquelle le produit sera installé, ne pas monter le produit.
4. **Pour le nettoyage du panneau** utiliser seulement un détachant à sec en suivant soigneusement les instructions sur le produit utilisé.
5. **Ne pas utiliser de détergents pour nettoyer les pièces qui ne sont pas en tissu.** Nettoyer seulement avec un chiffon humidifié avec de l'eau.
6. Pour toute information complémentaire sur les modalités d'installation, contacter le revendeur. Pour emploi différent par rapport à ceux indiqués ici nous vous prions de contacter le revendeur.
7. Pour compléter le montage du produit, suivez les instructions concernant le support choisi

#### **¡ADVERTENCIAS!**

**Antes de realizar el montaje y la instalación del producto leer atentamente las advertencias que se indican a continuación, prestando especial atención a los dibujos y a las instrucciones para el montaje. Consultar estas advertencias cada vez que se monte y/o instale el producto .**

1. El montaje y la instalación del producto debe efectuarlo exclusivamente personal técnico competente. Atención: una vez acabado el montaje, hay que comprobar siempre que la estructura realizada sea apta para el tipo de servicio y/o uso al que se va a destinar. Los productos no son aptos para niños.
2. Antes de realizar la instalación es necesario controlar la capacidad de carga de la superficie en la que se colocará el producto :por consiguiente, hay que utilizar dispositivos de fijación adecuados para el tipo de superficie capaces de resistir las fuerzas generadas. Atención: la superficie del suelo debe en cualquier caso ser horizontal, plana, rígida e indeformable.
3. Atención: en caso de duda sobre las modalidades de instalación y/o sobre la capacidad de carga de la superficie en la que se vaya a colocar el producto, éste no deberá instalarse.
4. **Para la limpieza del panele** utilizar exclusivamente un producto quitamanchas en seco, siguiendo atentamente las instrucciones que aparecen sobre el producto utilizado
5. **No utilizar detergents para las partes que no son tejidos.** Usar solamente con un tarpo humedecido con agua.
6. Para más información sobre las modalidades de instalación del producto, ponerse en contacto con el vendedor. Para cualquier otra utilización por favor consulte con su distribuidor.
7. Para completar el montaje del producto, siga las instrucciones para el soporte elegido