

SNOWSOUND®

Acoustic Panels & Fibers

MOD. 513-A/ L0

BOTANICA

Distributed by Snowsound USA

Design: Mario Trimarchi

(x = colour alternative, variante couleur, variante color)

40037009

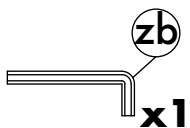
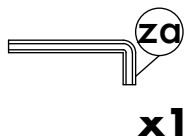
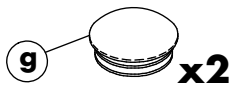
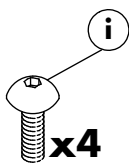

40037010

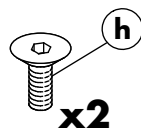
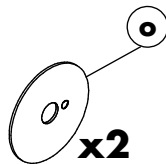
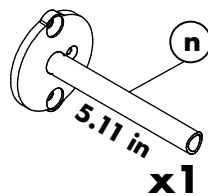
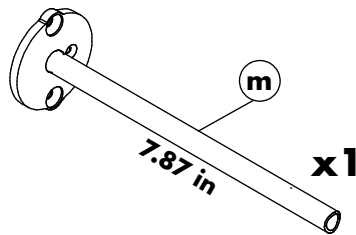

40037XXX

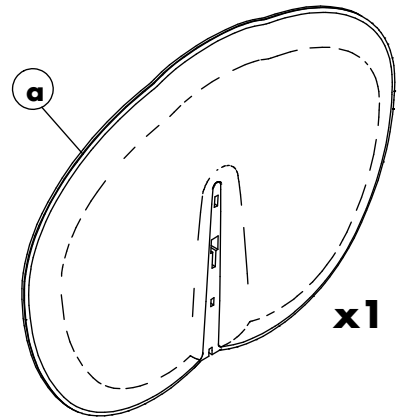

40037001

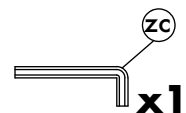
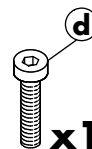
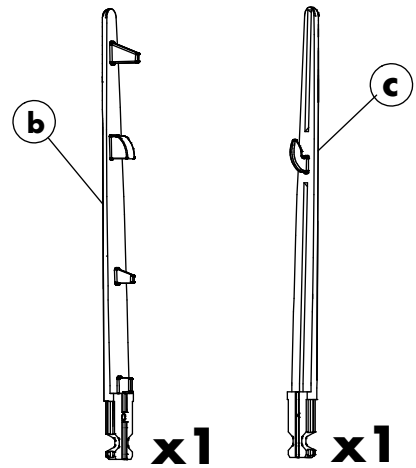

40037007

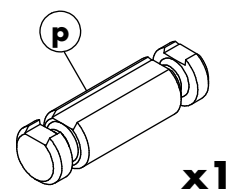

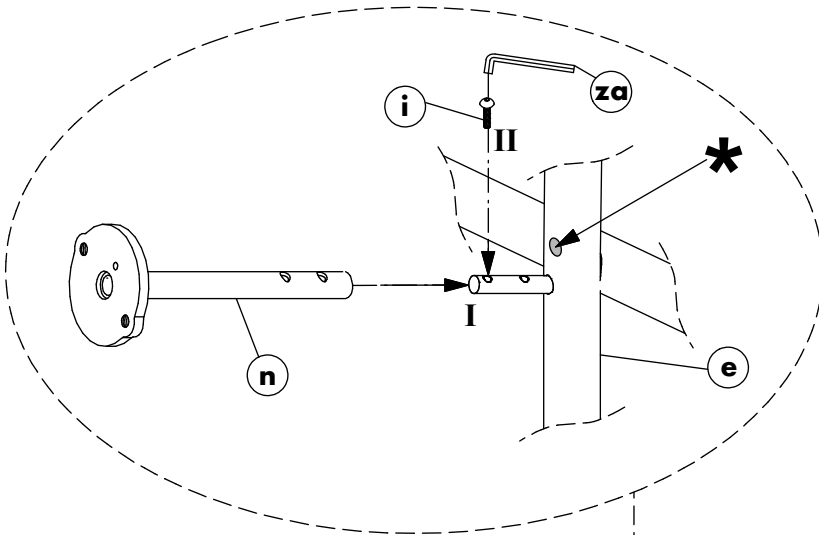
1

- Pay attention to the assembly direction. Mount the element (n) at the mark(*) on the structure (e).
- Attention au sens de montage. Fixer l'élément (n) en correspondance du signe(*) sur la structure (e).
- Preste atención al sentido de montaje. Monte el elemento (n) en correspondencia con el signo(*) en la estructura (e).

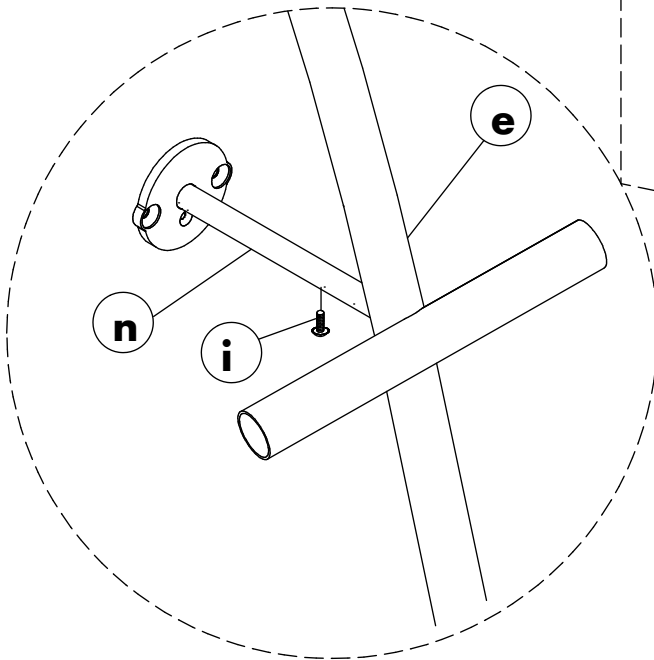

- use only one screw (i)
- utiliser une seule vis (i)
- usa solo un tornillo (i)

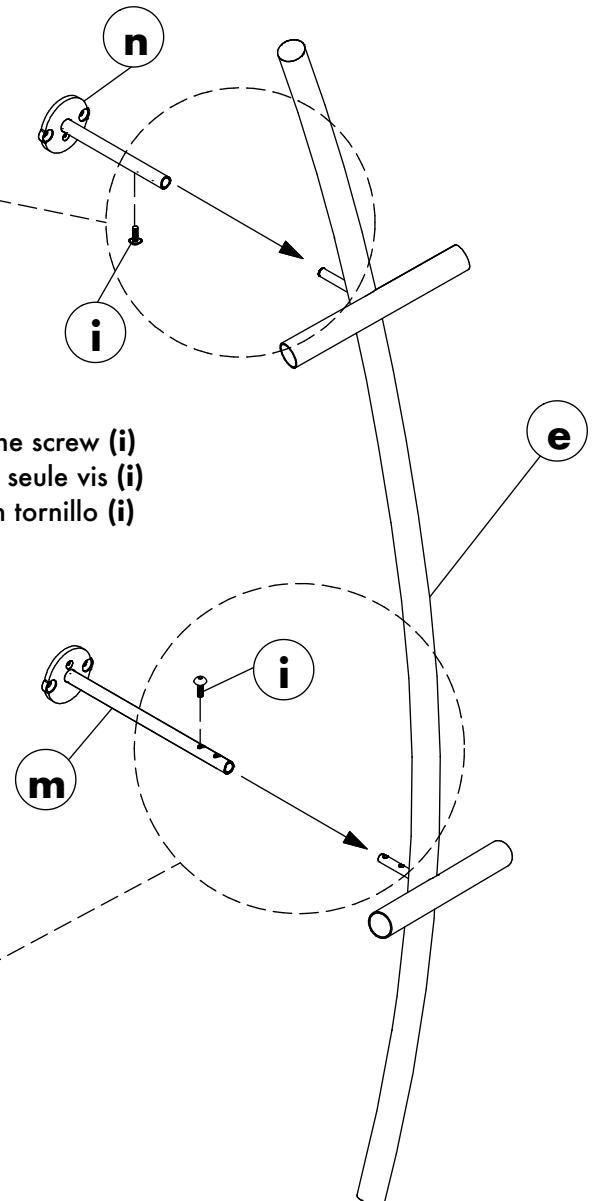

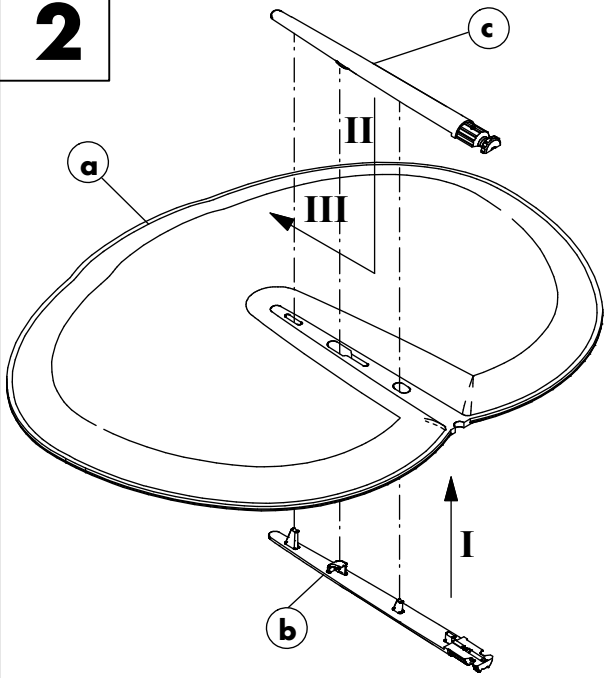
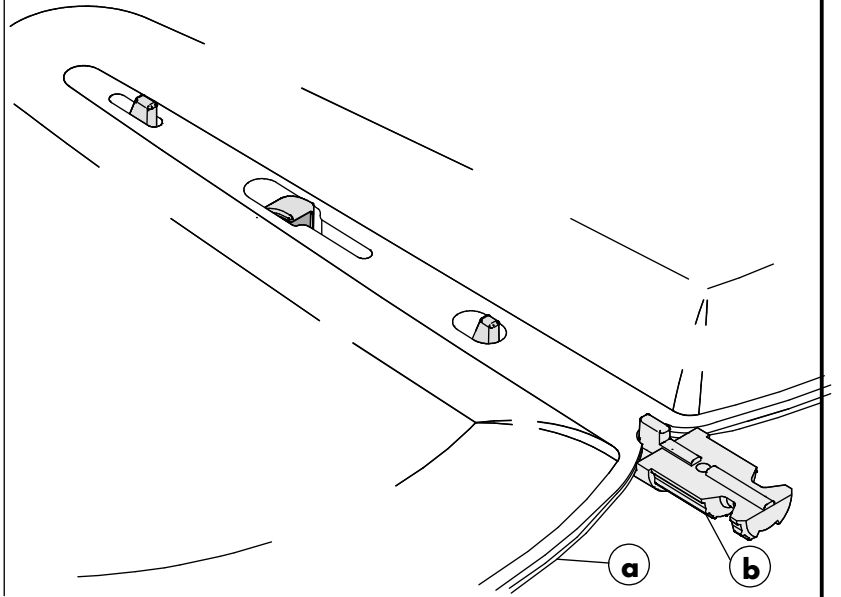
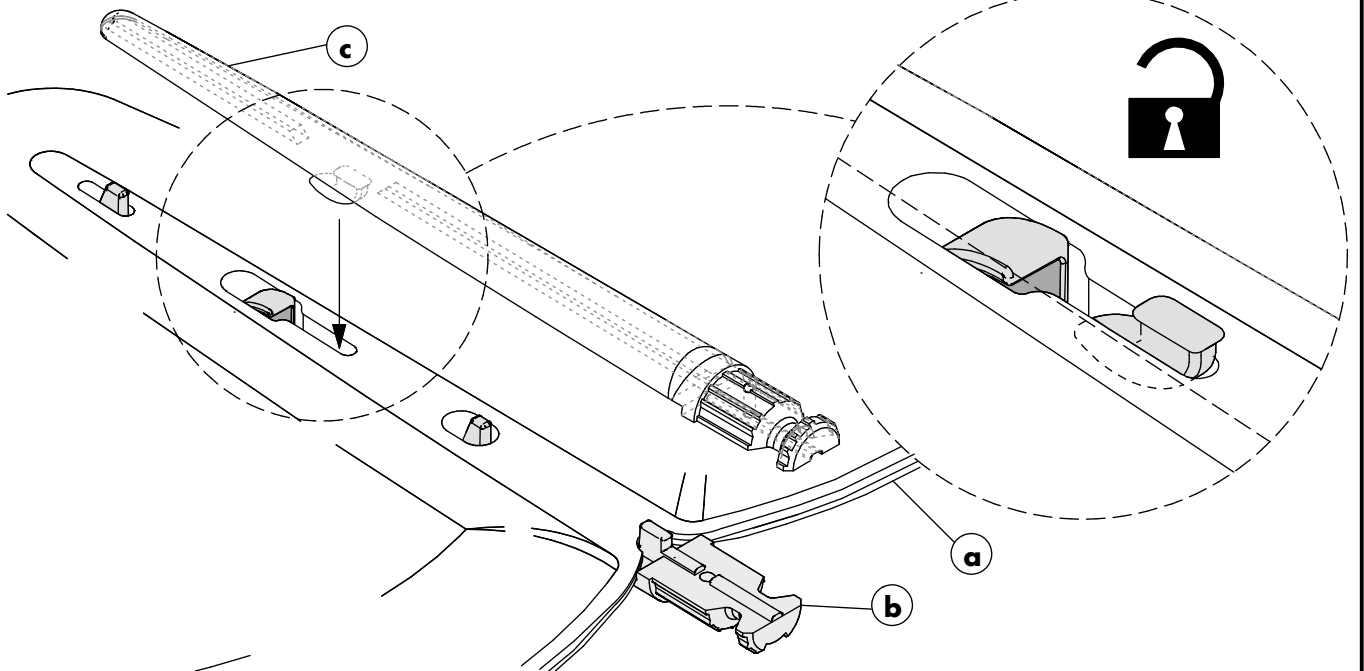
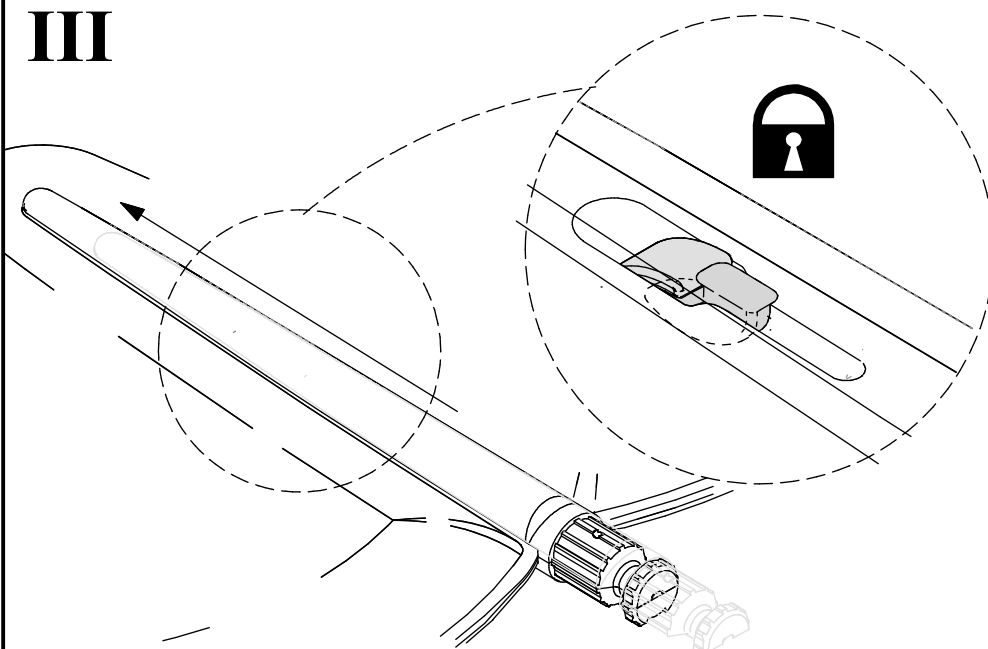
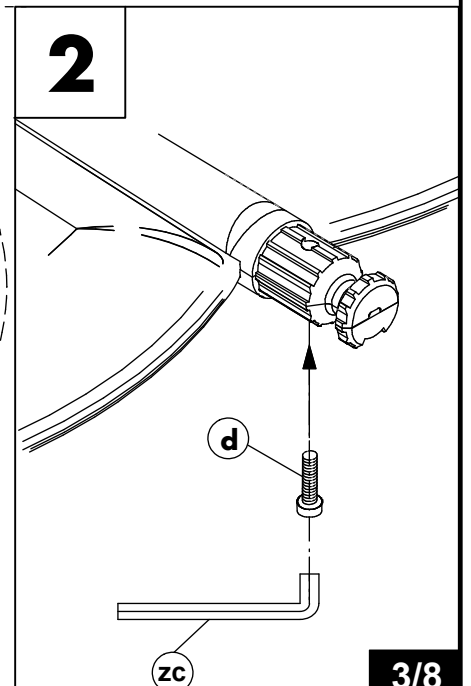
2**I****II****III****2**

zc

3/8

3

ATTENTION : Align the cavity of the element **b** with the hole of the element **e**

ATTENTION : Aligner la cavité de l'élément **b** avec le trou de l'élément **e**

ATENCIÓN : Alinear la cavidad del elemento **b** con el agujero del elemento **e**

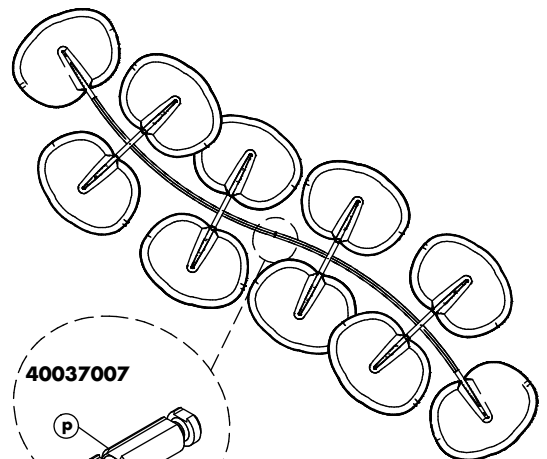
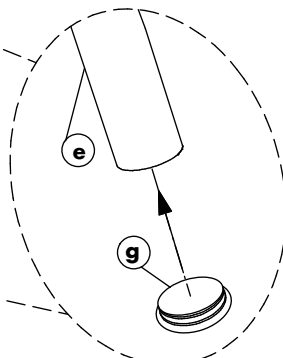
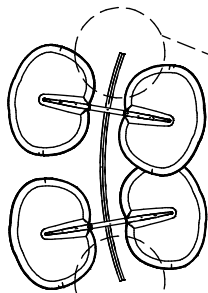
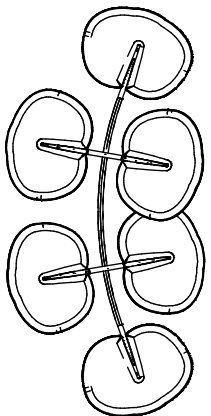
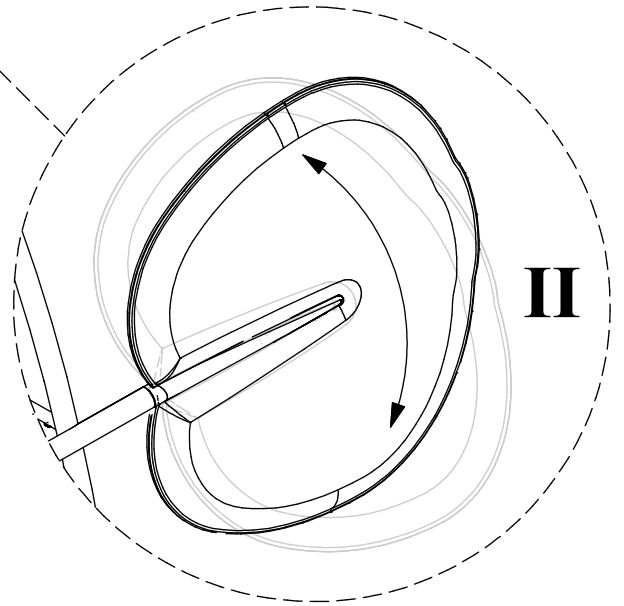
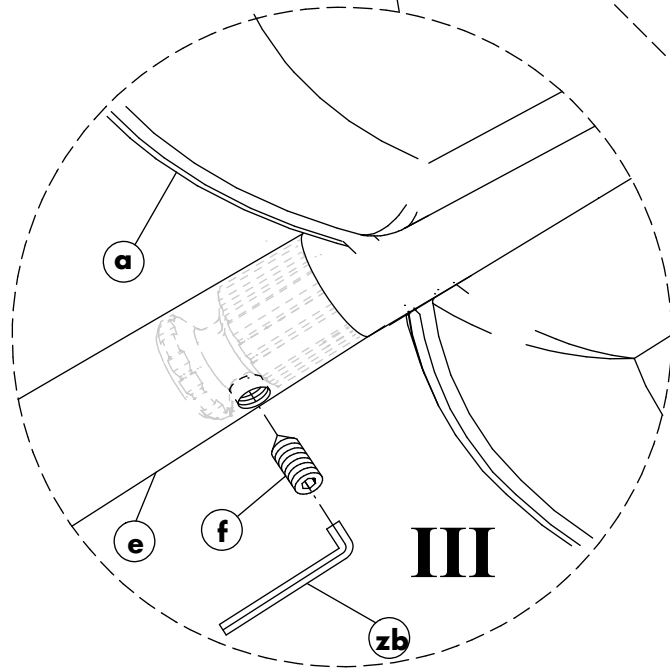
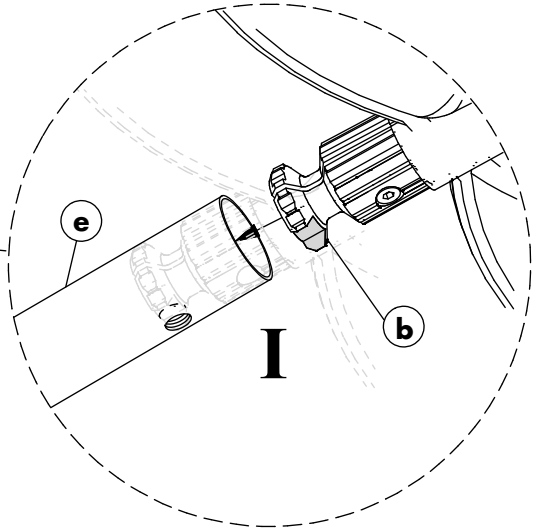
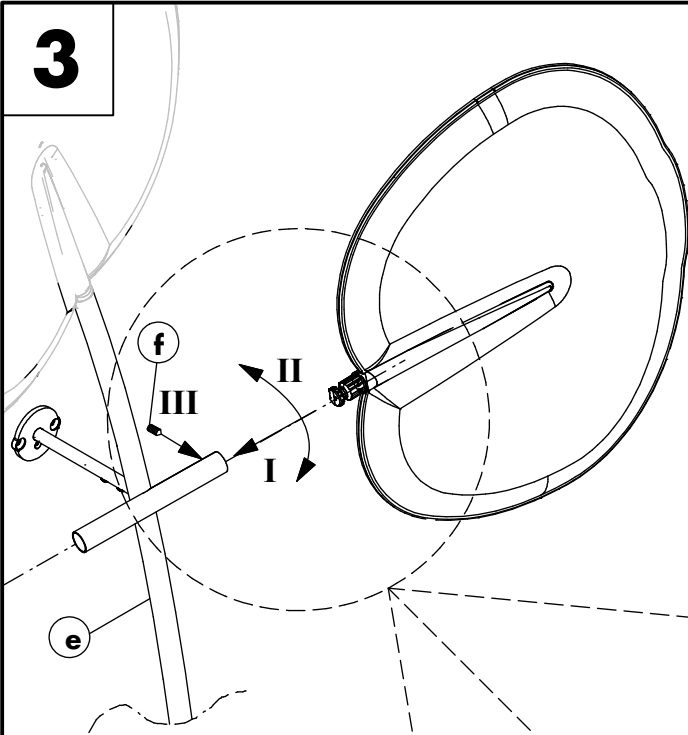

40037007

P

4

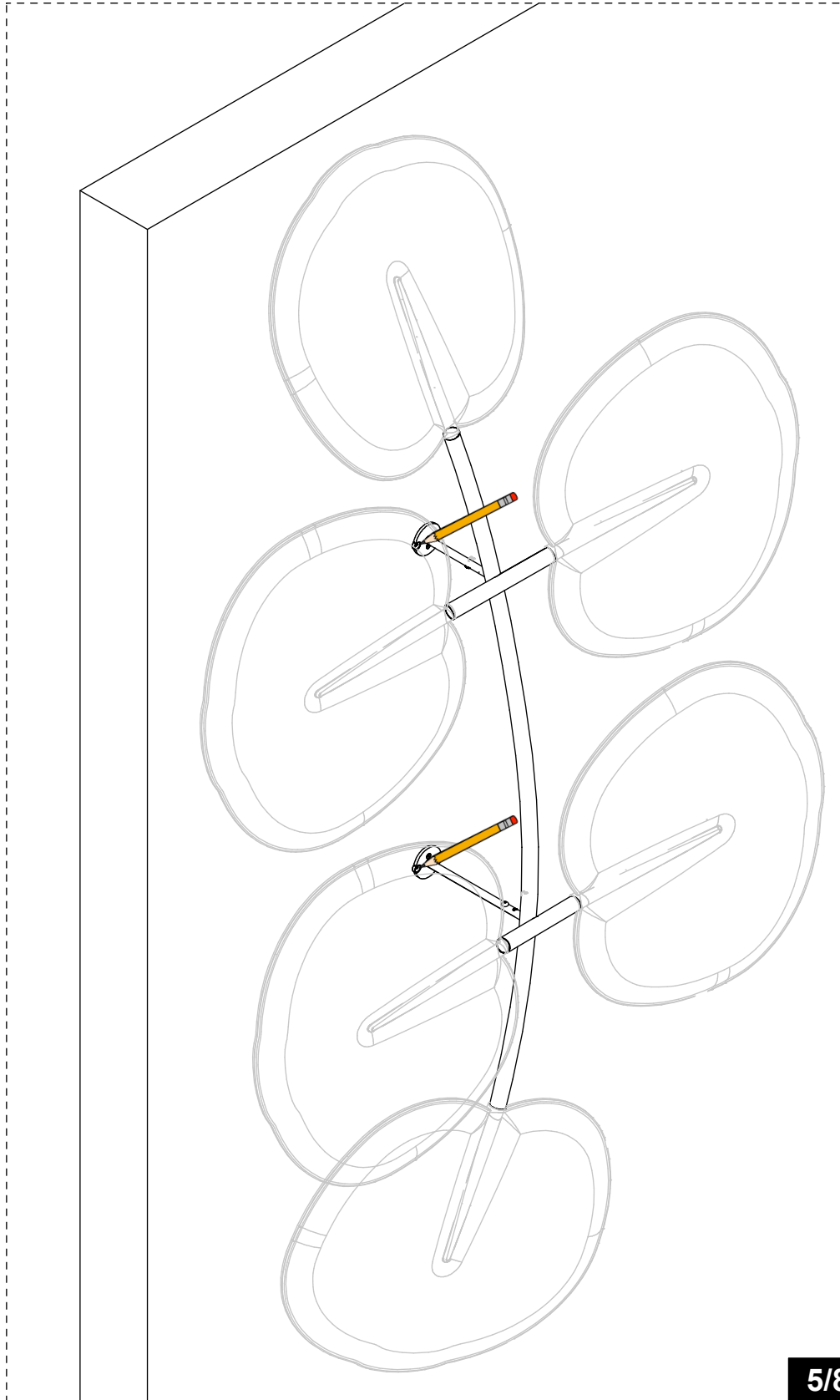
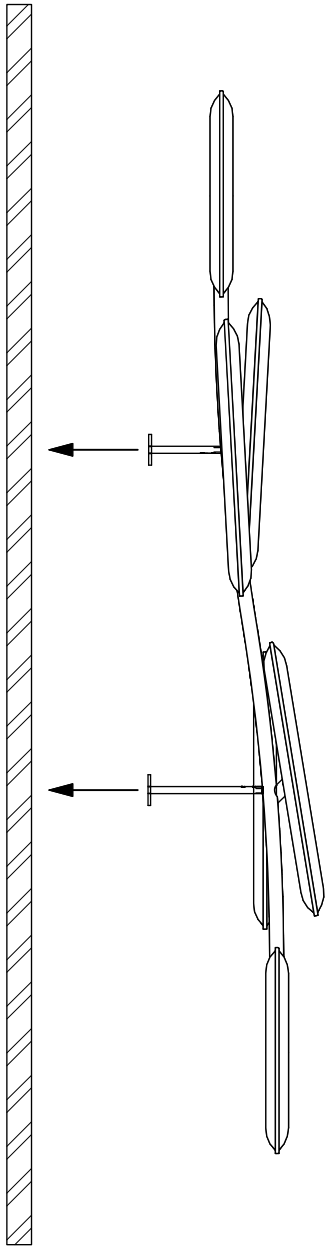
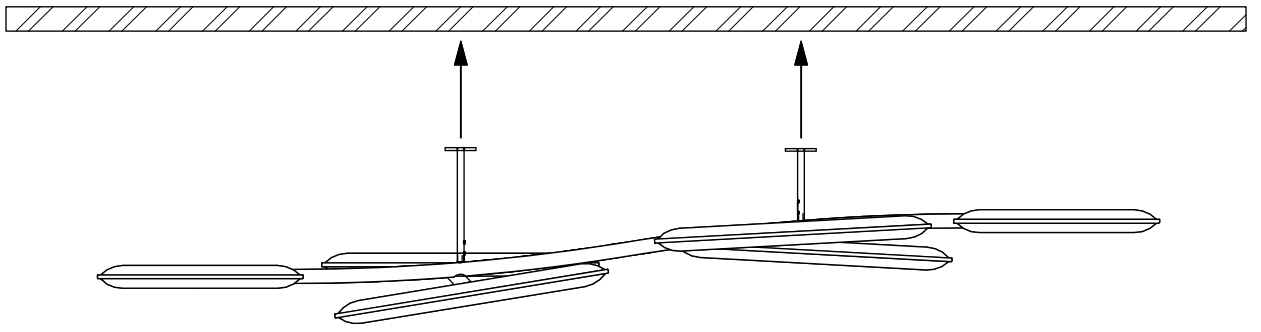

5

- remove the structure and fix the wall brackets
- enlever la structure et fixer les supports muraux
- retirar la estructura y fijar los soportes de pared

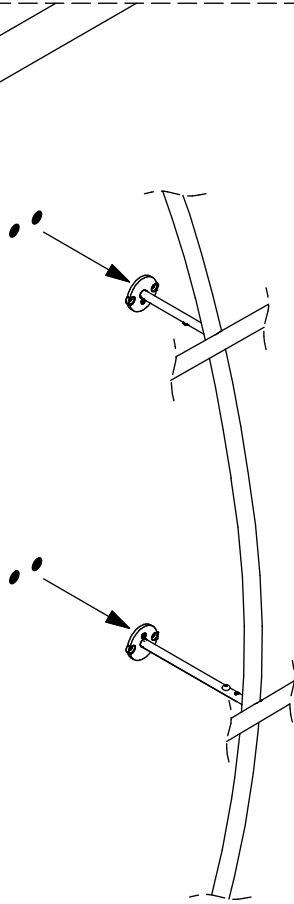
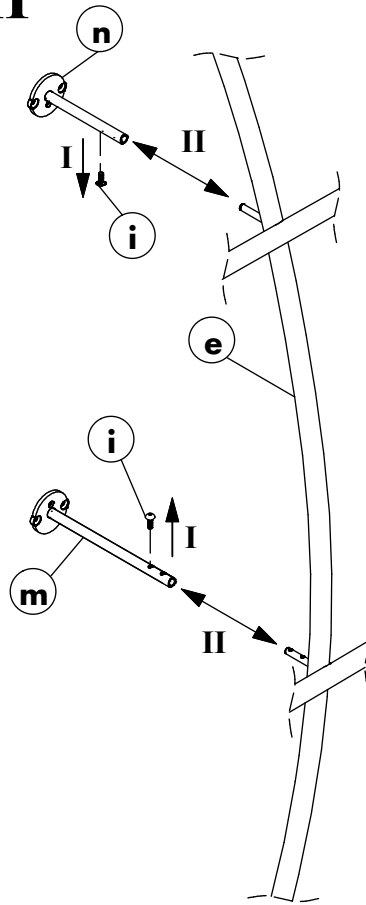
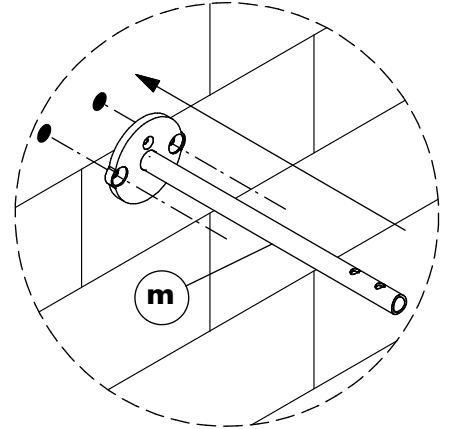
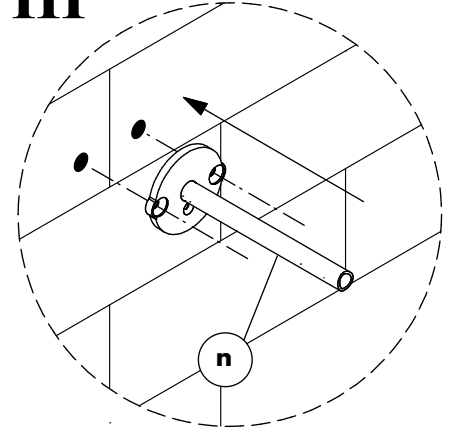
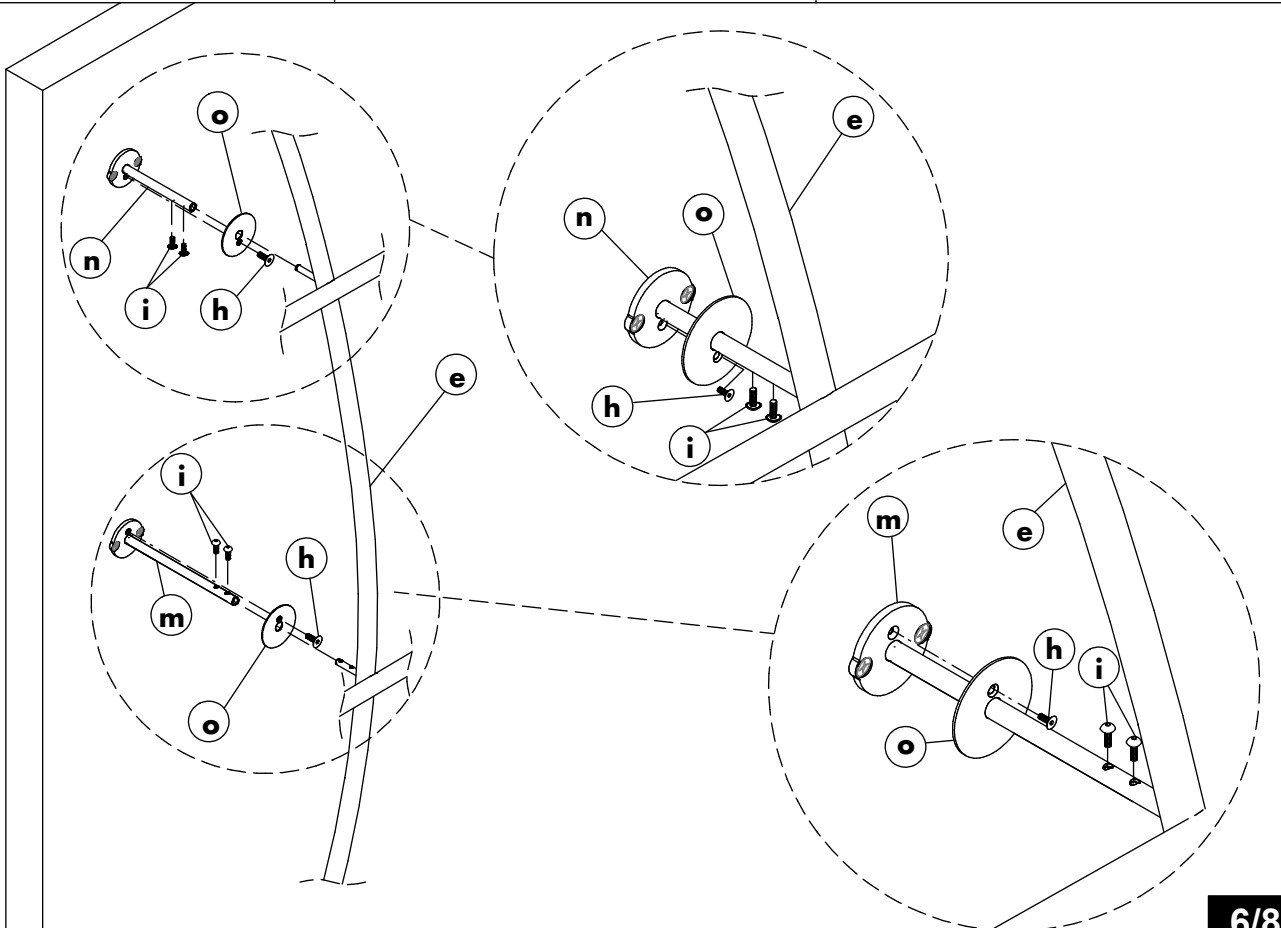
I**II****III****6**

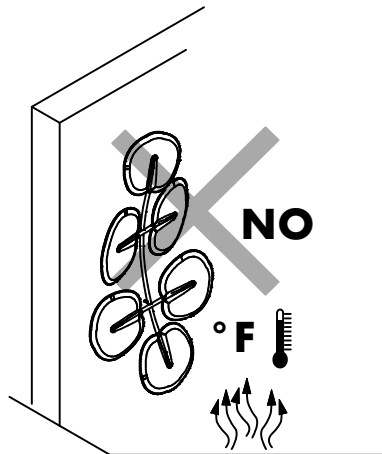
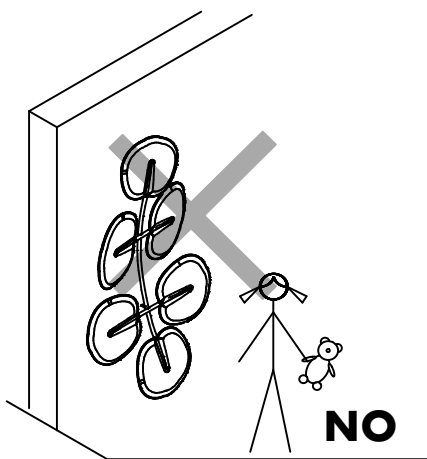
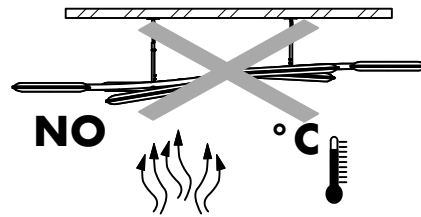
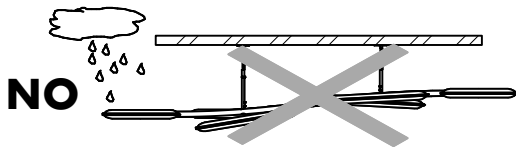
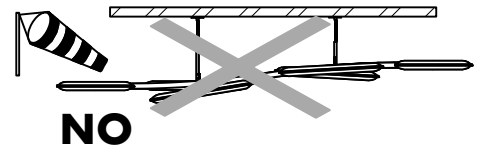
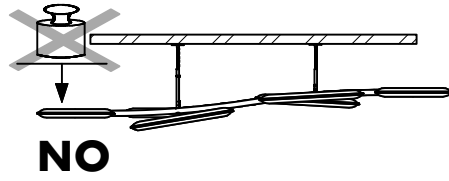
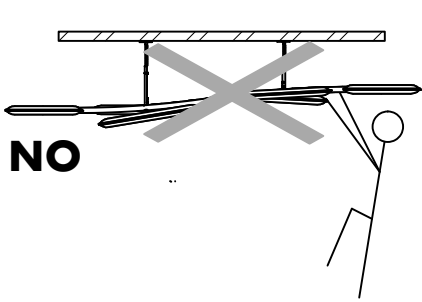

- keep away from heat sources
- tenir loin de sources de chaleur
- mantener alejado de fuentes de calor

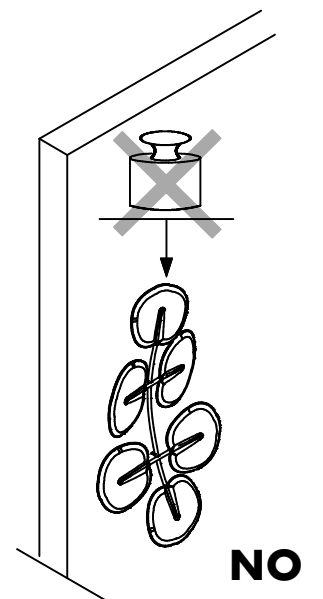
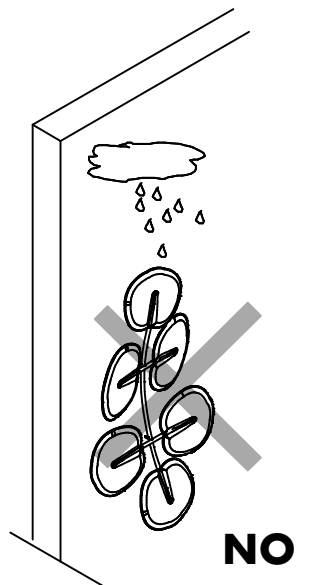
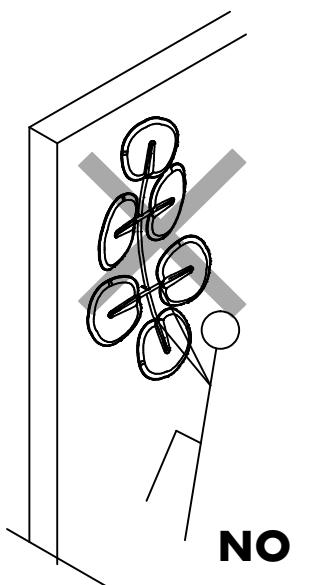

Congratulations on your latest SNOWSOUND purchase. Follow these instructions and you'll have this new product mounted in no time. If you need any help, or to order replacement/missing parts, please call **1-800-747-2660** or email "info@snowsoundusa.com"

NOTE!

Prior to assembling and installing the unit please read the following notes carefully. Pay particular attention to the drawings in the assembly instructions. Please consult these notes every time the product is assembled and/or installed.

1. The product must only be assembled and installed by qualified contractors. Warning: once the product has been assembled always check that the structure is suitable for the type of application and/or use to which it will be put. These products are not suitable for use by children.
2. Prior to installation check the load bearing capacity of the surface on which the product is to be fitted :use suitable fixtures according to the type of surface which must be able to withstand the forces generated.
3. Warning: if you have any doubts concerning how to install the product and/or the load bearing capacity of the surface on which it will fitted, do not fit it.
4. Do not use detergents to clean the parts that are not in textile fabric.
5. To clean the panel use only a dry stain removal, carefully following the instructions on the product used.
6. For further information on how to install the product, please contact your dealer. For any use different from the ones here shown please contact the dealer.
7. To complete the assembling of the products please follow the instructions related to the chosen support

MISES EN GARDE!

Avant de procéder au montage et à l'installation du produit, lire attentivement les mises en garde ci-dessous présentées, en faisant particulièrement attention aux dessins explicatifs rapportées dans les instructions de montage. Consulter ces mises en garde lors de chaque montage successif et/ou installation du produit.

1. Le montage et l'installation du produit doivent exclusivement être effectués par un personnel technique compétent. Attention: au terme du montage, toujours vérifier si la structure réalisée est appropriée au type d'usagers et/ou d'utilisation auxquels elle est destinée. Les produits ne sont pas destinés aux enfants.
2. Avant de procéder à l'installation, il est nécessaire de vérifier la capacité de charge de la surface sur laquelle le produit sera installé :en conséquence, utiliser les dispositifs de fixation adaptés au type de surface et qui peuvent résister aux forces produites.
3. Attention: en cas de doute sur les modalités d'installation et/ou sur la capacité de charge de la surface sur laquelle le produit sera installé, ne pas monter le produit.
4. Pour le nettoyage du panneau utiliser seulement un détachant à sec en suivant soigneusement les instructions sur le produit utilisé.
5. Ne pas utiliser de détergents pour nettoyer les pièces qui ne sont pas en tissu.
6. Pour toute information complémentaire sur les modalités d'installation, contacter le revendeur. Pour emploi différent par rapport à ceux indiqués ici nous vous prions de contacter le revendeur.
7. Pour compléter le montage du produit, suivez les instructions concernant le support choisi

¡ADVERTENCIAS!

Antes de realizar el montaje y la instalación del producto leer atentamente las advertencias que se indican a continuación, prestando especial atención a los dibujos y a las instrucciones para el montaje. Consultar estas advertencias cada vez que se monte y/o instale el producto .

1. El montaje y la instalación del producto debe efectuarlo exclusivamente personal técnico competente. Atención: una vez acabado el montaje, hay que comprobar siempre que la estructura realizada sea apta para el tipo de servicio y/o uso al que se va a destinar. Los productos no son aptos para niños.
2. Antes de realizar la instalación es necesario controlar la capacidad de carga de la superficie en la que se colocará el producto :por consiguiente, hay que utilizar dispositivos de fijación adecuados para el tipo de superficie capaces de resistir las fuerzas generadas. Atención: la superficie del suelo debe en cualquier caso ser horizontal, plana, rígida e indeformable.
3. Atención: en caso de duda sobre las modalidades de instalación y/o sobre la capacidad de carga de la superficie en la que se vaya a colocar el producto, éste no deberá instalarse.
4. Para la limpieza del panel utilizar exclusivamente un producto quitamanchas en seco, siguiendo atentamente las instrucciones que aparecen sobre el producto utilizado
5. No utilizar detergents para las partes que no son tejidos.
6. Para más información sobre las modalidades de instalación del producto, ponerse en contacto con el vendedor. Para cualquier otra utilización por favor consulte con su distribuidor.
7. Para completar el montaje del producto, siga las instrucciones para el soporte elegido