



CUBBY 28"L x 28"W x 20.5"D - COMPLETE KIT

QUICK SHIP	COLOR	PART #	QUICK SHIP	COLOR	PART #
	RED	40020097		SILVER GRAY	40020098

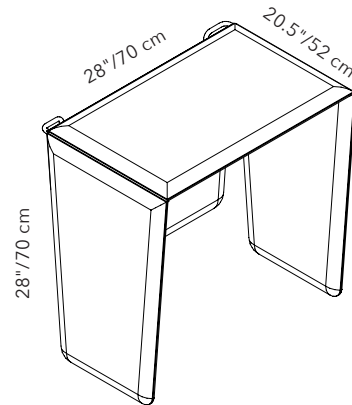

CUBBY is a comfortable phone booth composed of panels with sound-absorbing polyester foam covered in an external sound-absorbing polyester fabric which can be easily cleaned. It also features an independent load-bearing angled shelf in powder coated steel. The soft side-panels can move freely if bumped.

ANGLED SHELF FOR CUBBY - OPTIONAL

PART #	QTY	FINISH
40021090	1	SILVER

- Polyester internal padding with Snowsound technology, polyester covering in Trevira CS® fabric
- Single material and 100% recyclable
- Eco friendly - Greenguard Gold
- Durable, tackable double-sided surface
- Class A fire and smoke safety (UL 723/ASTM E84)
- CAL 133, 117 pass
- Sleek profile
- Wall mounted

